

Particle physics at the BNL Electron-Ion Collider

Alessandro Tricoli (BNL)



APS Global Physics Summit
Denver, Colorado
March 15-20, 2026

Big Questions in Particle Physics

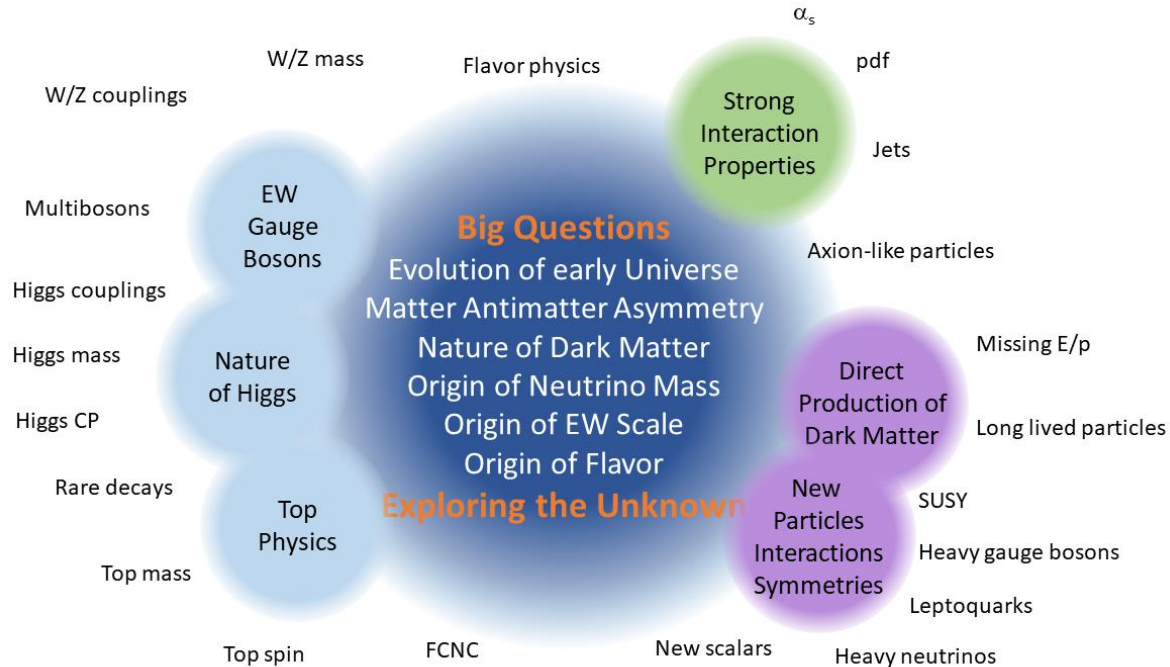

Energy vs Luminosity

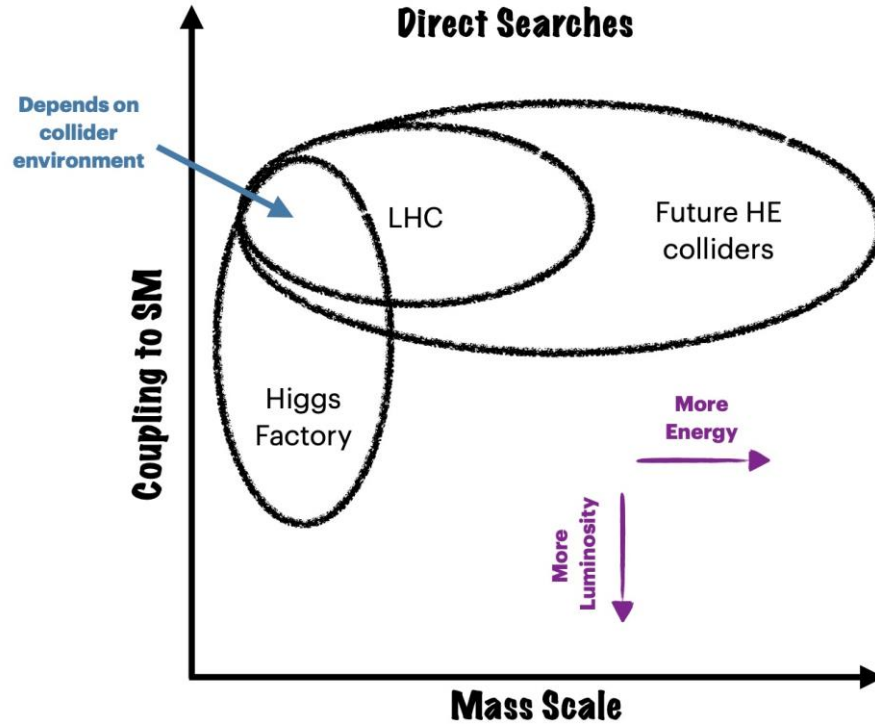

Energy vs Luminosity

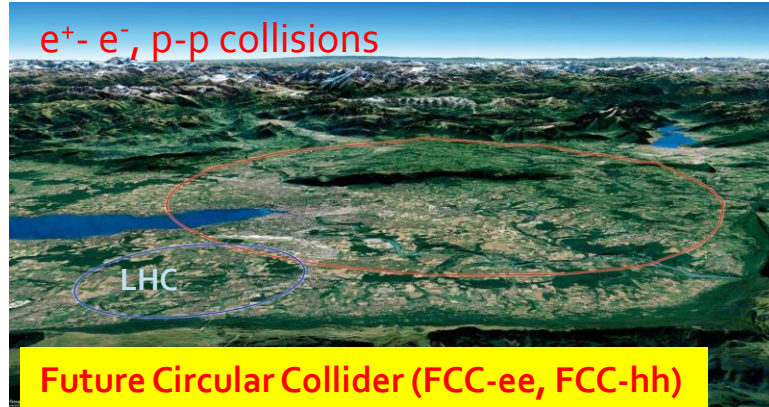
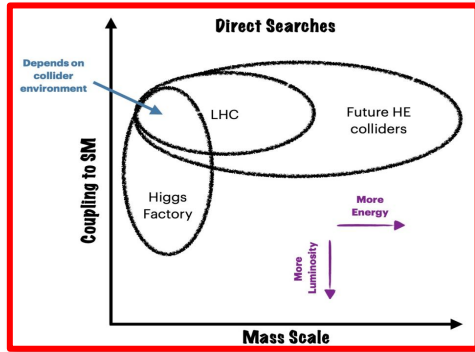

Energy vs Luminosity

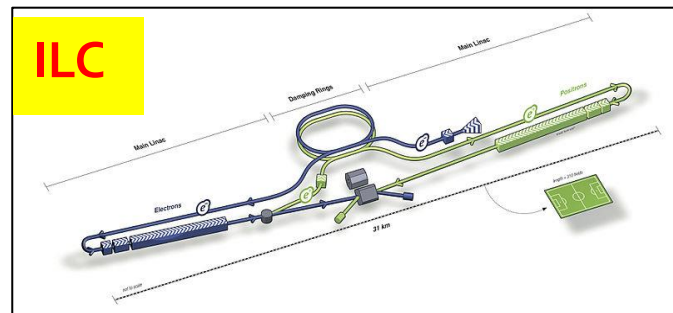
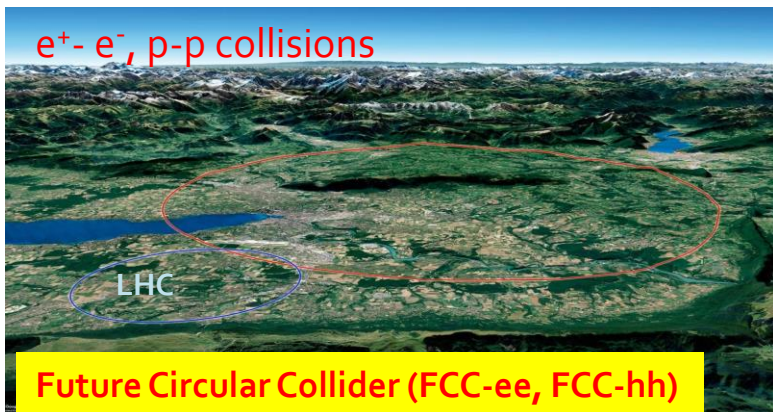
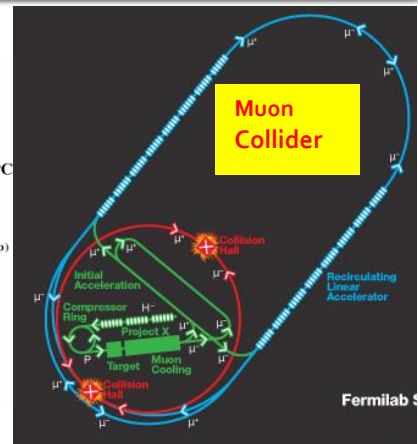
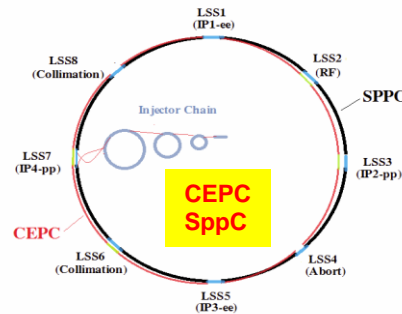
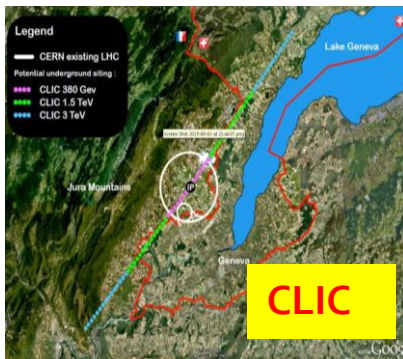
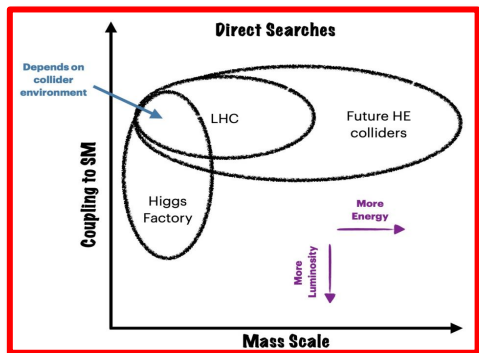

Energy vs Luminosity

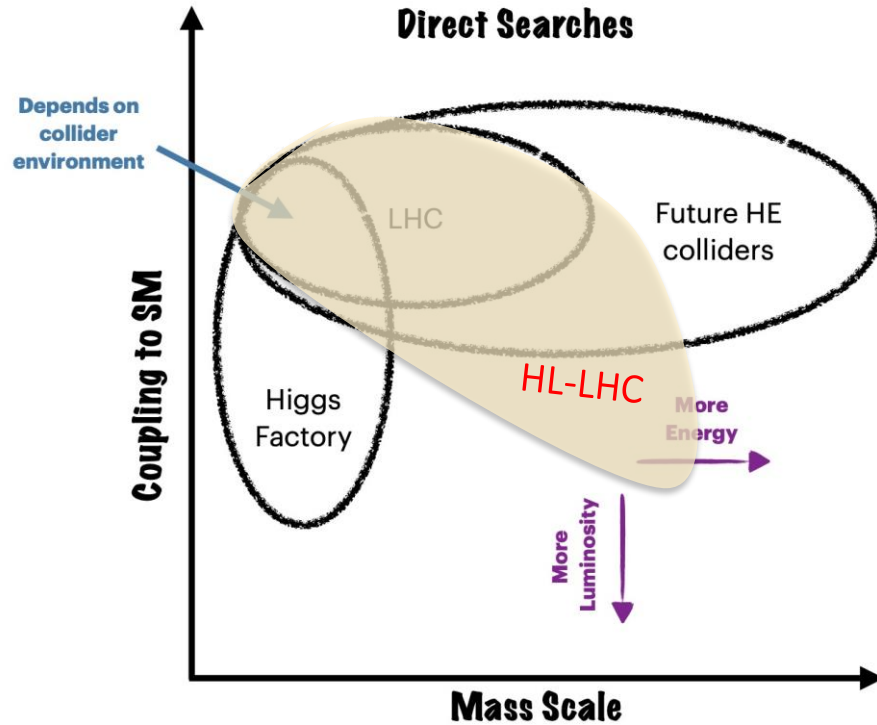

Energy vs Luminosity

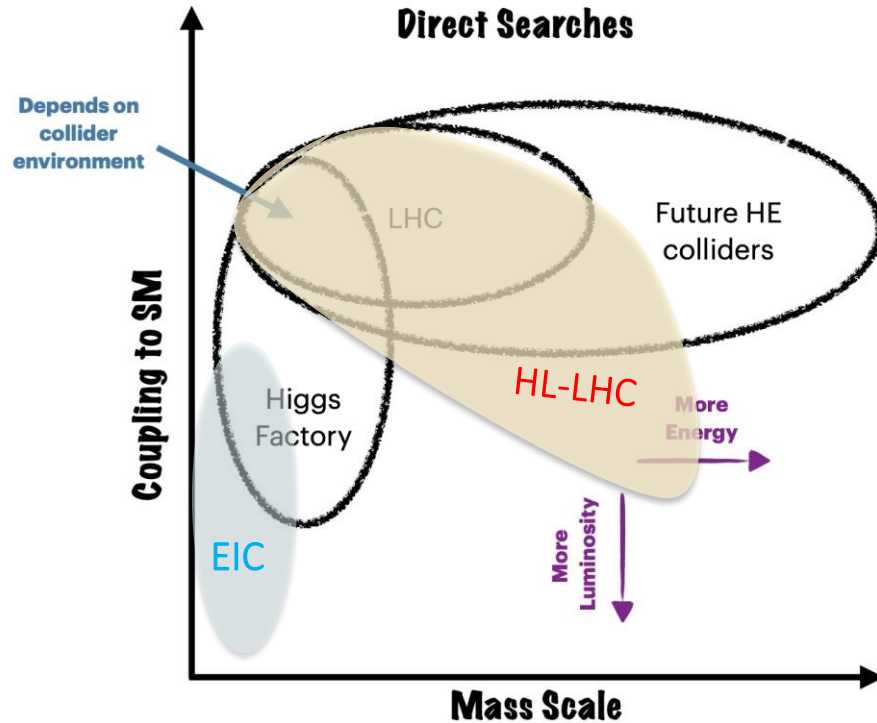

The Electron Ion Collider (EIC)

- ❖ A high-luminosity (1000x HERA), high-polarization, precision machine to yield electron-scattering
 - From **Heavy nuclei** (including with a wide variety of species)
 - From **Polarized protons (and light ions)** both longitudinal and transverse

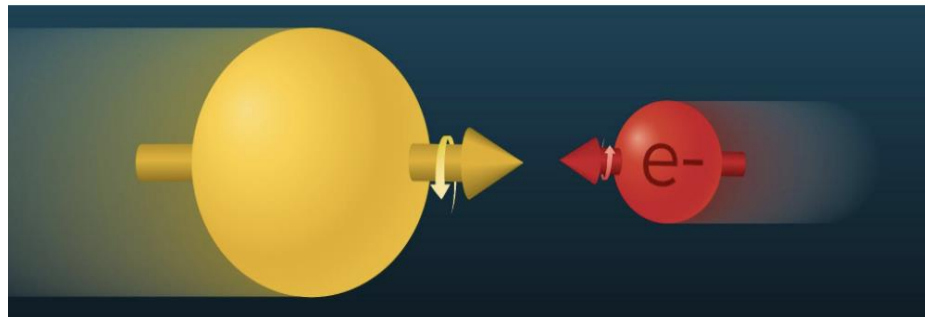
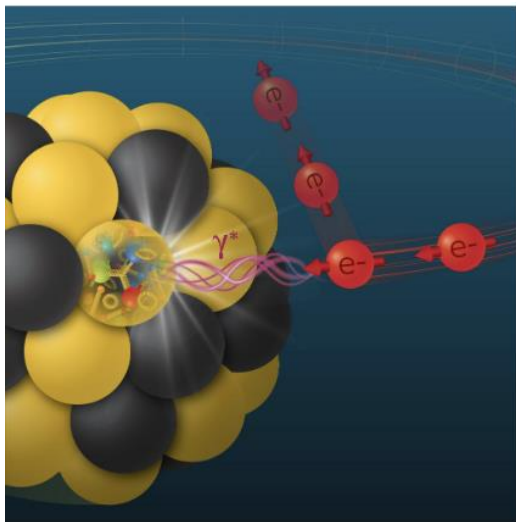

Studying nuclear matter at EIC

By Abhay Deshpande



A-A (RHIC/LHC)
Violent collision of
melons

Study of internal structure of a watermelon



e-A (EIC)
Cutting the watermelon with a knife
Electron Beam acts as a Scalpel

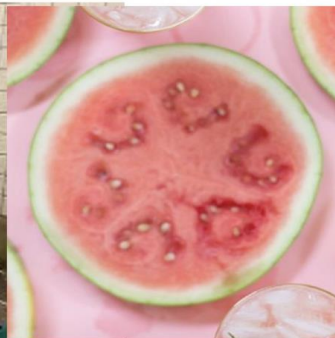

Non-Violent e-A (EIC)
Image internal structure
MRI of a watermelon

Tomography



The EIC Program

Strong Interactions



Does the mass of visible matter emerge from quark-gluon interactions?

Quarks and gluons comprise 2% of the proton's mass



How do quarks, gluons, and orbital angular momentum contribute to proton spin?

Spin: a fundamental property of matter



How can we understand the QCD dynamics and the relation to Confinement?

EIC will image quarks and gluons in 3D in space and momentum inside the nucleon and nuclei



How do the quark-gluon interactions create nuclear binding?

Is the structure of a free and bound nucleon the same?

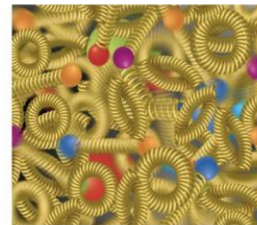

Does gluon density in nuclei saturate at high energy?

How many gluons can fit in a proton?

Electroweak Beyond-SM

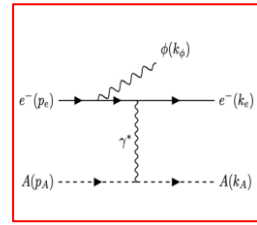

Is there new physics at very low masses and couplings?

Search for new physics and measure electroweak parameters

The EIC

- ❖ **The EIC** is a unique, high-energy, high-luminosity, polarized beam collider that will be one of the most challenging and exciting accelerator complexes ever built

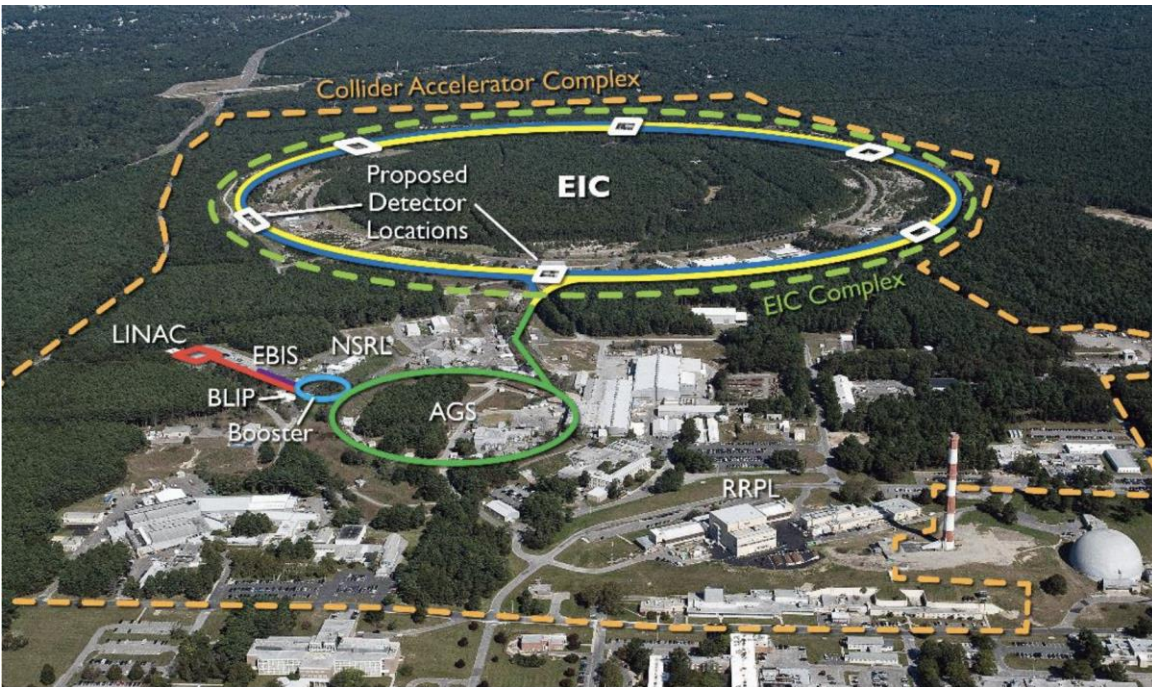

- **EIC will be built in RHIC tunnel at BNL**
- **RHIC concluded operations** in February 2026 (25 years of operations)
- **EIC is the only particle physics collider to be built in the next decade in the US** (startup expected in 2035)
- **The EIC design is stable and mature**

The EIC

- ❖ **The EIC** is a unique, high-energy, high-luminosity, polarized beam collider that will be one of the most challenging and exciting accelerator complexes ever built

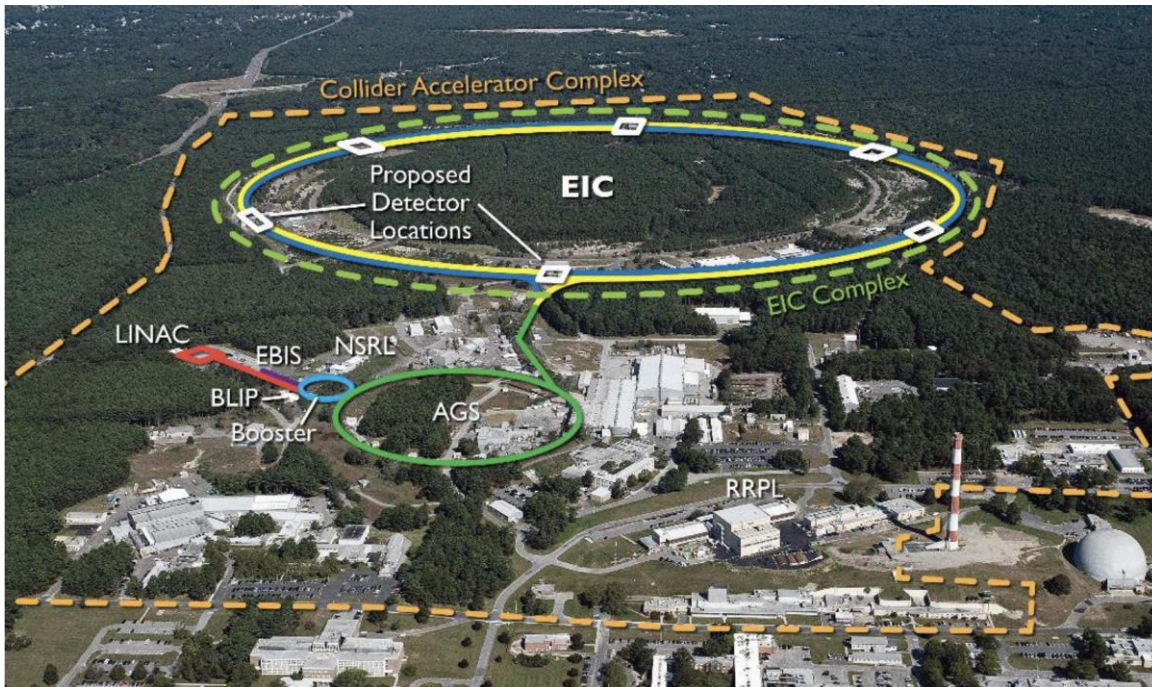

- **EIC will be built in RHIC tunnel**
- **RHIC concluded operations** in January 2026 (25 years of operations)
- **EIC is the only particle physics collider to be built in the next decade** (start in 2035)
- **The EIC design is stable and mature**

- **High Luminosity:**
 - Instantaneous $L = 10^{33} - 10^{34} \text{ cm}^{-2}\text{sec}^{-1}$
 - Integrated $L = 10 - 100 \text{ fb}^{-1}/\text{year}$
- **Highly Polarized Beams: 70%**
 - e^- , p , and light ion beams
- **Large Center of Mass Energy Range:**
 - $E_{\text{cm}} = 28 - 100 \text{ GeV}$ (upgradable to 140 GeV)
- **Large Ion Species Range: Protons – Uranium**
- **Possibly more than one Interaction Regions**

Transition from RHIC to EIC

Ion-Ion Collider

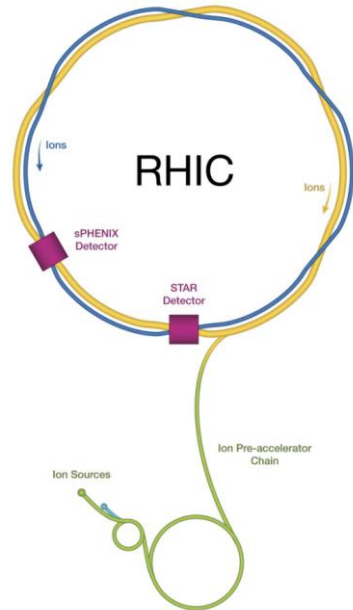

Transition from RHIC to EIC

Ion-Ion Collider

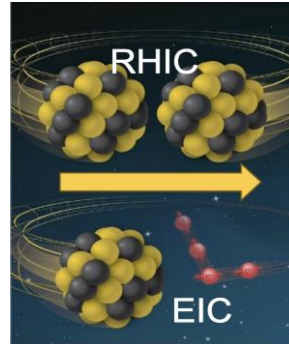
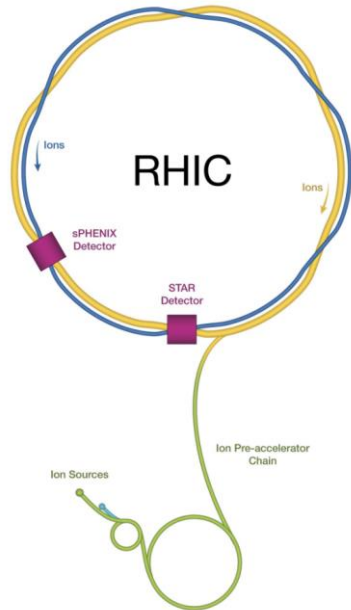

Electron-Ion Collider

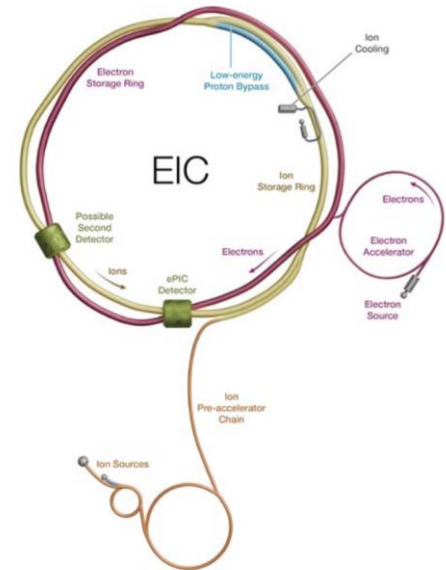

- **EIC benefits from BNL infrastructure, RHIC and Injectors**
 - Re-use existing tunnel
 - Minimal modification to the hadron beam complex (yellow)
- **New electron beam facility**

Transition from RHIC to EIC

Ion-Ion Collider

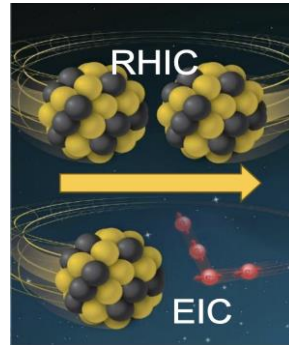
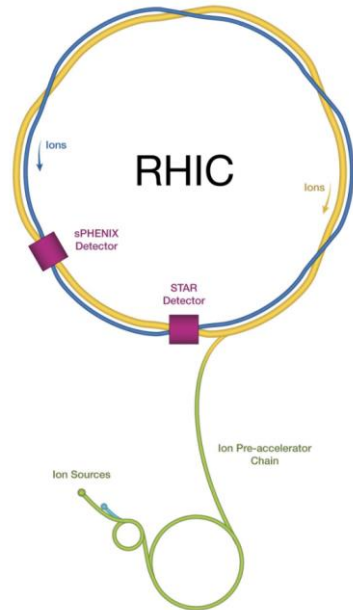

Electron-Ion Collider

Two Interaction Regions
- ePIC Detector
- 2nd Detector (possible)

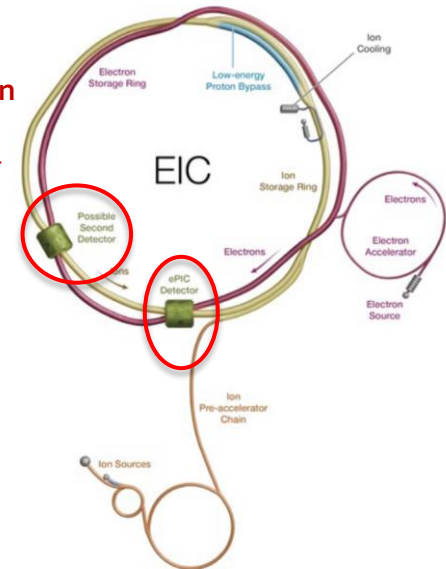

- **EIC benefits from BNL infrastructure RHIC and Injectors**
 - Re-use existing tunnel
 - Minimal modification to the hadron beam complex (yellow)
- **New electron beam facility**

The Road towards the EIC

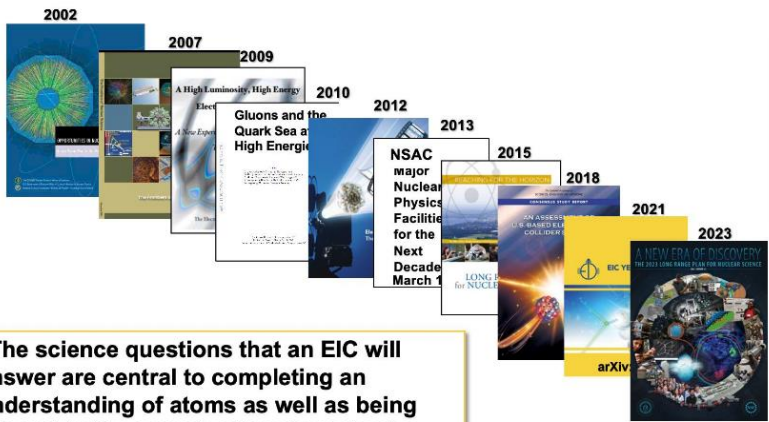

“We recommend the expeditious completion of the EIC as the highest priority for facility construction.” (NSAC LRP 2023)



“We note that cross domain collaboration and studies with the EIC measurements identified the synergies and complementarities in many physics studies, experimental technologies, analysis techniques, and theoretical tools.” (Snowmass 2021)

“The science questions that an EIC will answer are central to completing an understanding of atoms as well as being integral to the agenda of nuclear physics today.” (NAS, 2018)

“The EIC program will stimulate the development of theoretical and numerical tools for QCD at the interface between particle and nuclear physics.” (Snowmass 2021)

“The Electron-Ion Collider (EIC), for nuclear physics can provide key pathways to maintaining a vibrant US accelerator and collider workforce.” (P5 2023)

Pathways to Innovation and Discovery in Particle Physics
Report of the 2023 Particle Physics Project Prioritization Panel



“The planned construction of EIC offers a unique opportunity for strengthening the central role of the US scientific community in the field of particle physics, seen as a whole” (Snowmass 2021)

The EIC Collaboration

- **EIC US Partners** (performing work and/or providing components)
 - 8 DOE Labs
 - 22 universities
- **EIC Collaborators** (developing experiments, contributing expertise)
 - EIC User Group: 1,558 members and growing
 - 294 institutions worldwide (41 countries)
 - 80+ U.S. universities



CD-3A – April 2024
(Critical Decision to initiate long lead procurement)

➔

CD-2/3 (Accel. Storage), CD-2 (Det.)
 – Expected by end of 2026
(Critical Decision to start construction)

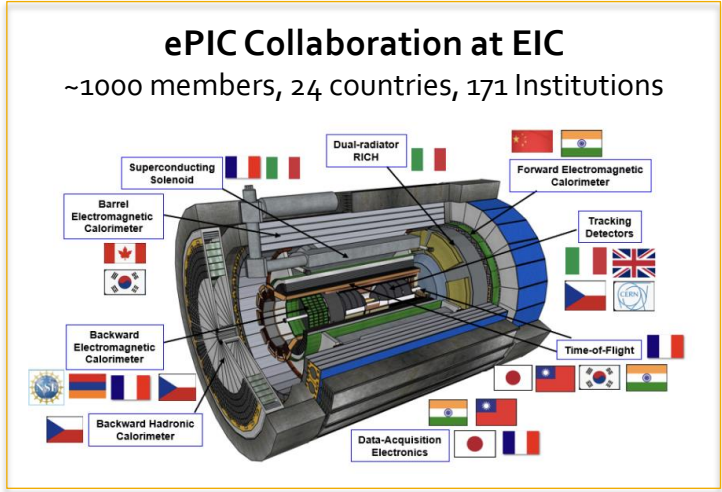
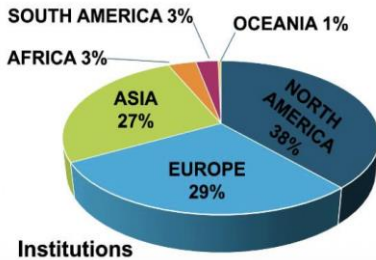

Synergies between EIC and HEP

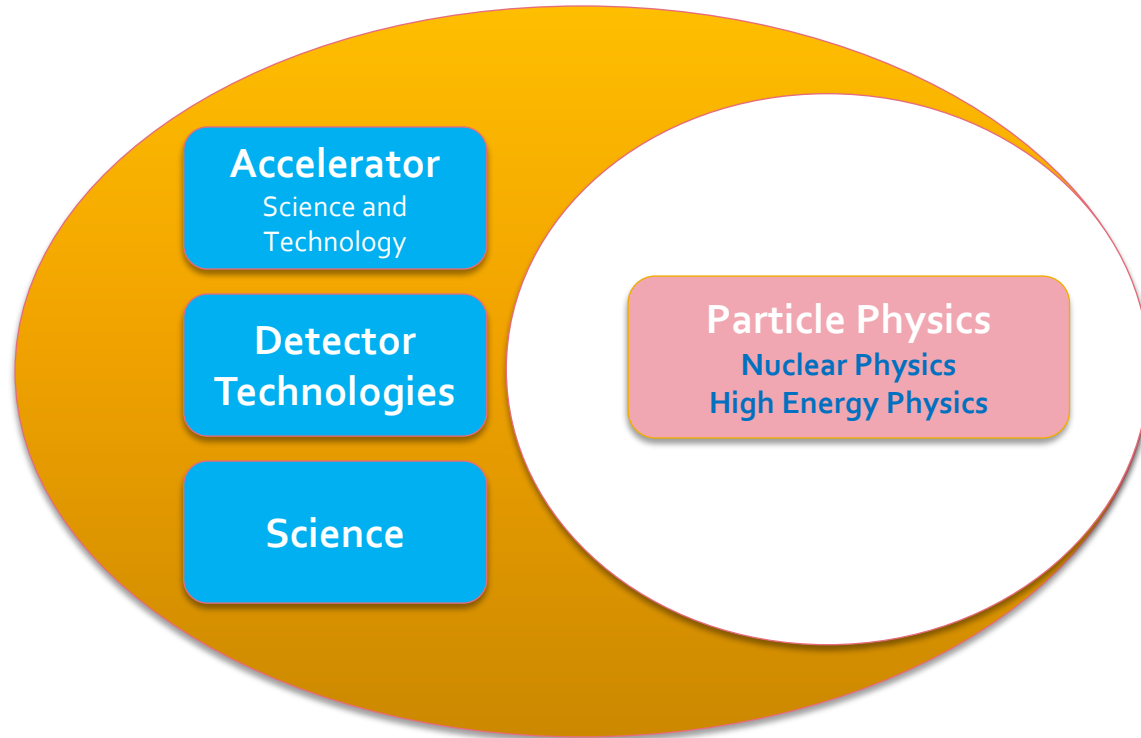

Such Synergies are recognized and discussed in several workshops

- [ECFA-NuPECC-APPEC "Synergies between the EIC and the LHC" \(Dec. 2023\)](#)
- [Synergies between the EIC and the LHC \(Jun. 2022\)](#)
- [CERN EP R&D Day \(Nov. 2021\)](#)

Synergistic Timelines

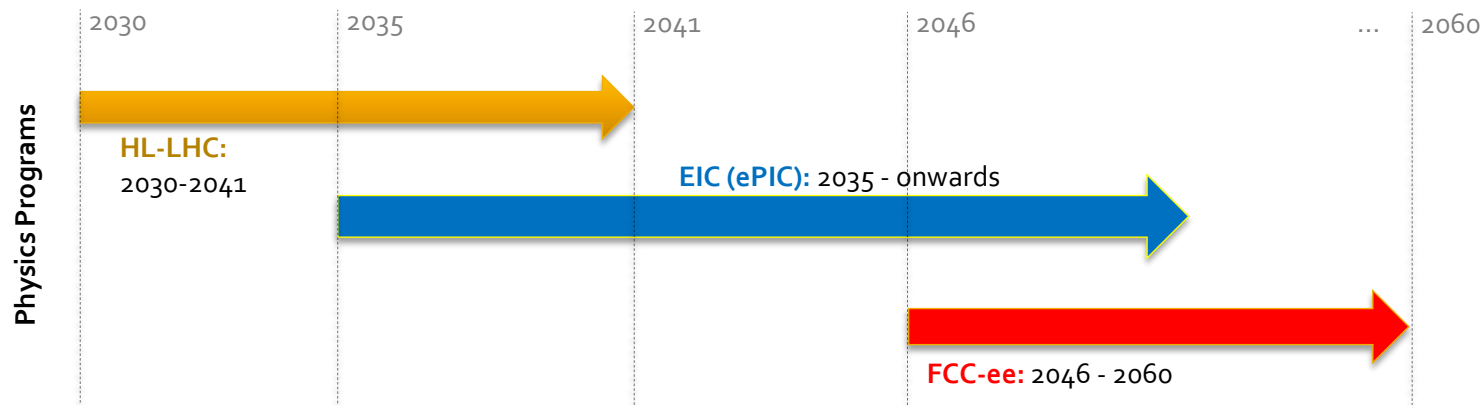

- ❖ Phasing of different colliders allows for global R&D with one experiment at a time driving the deployment of a technology → virtuous cycle
 - HL-LHC (HEP) → EIC (NP) → FCC (HEP)
- ❖ Partial overlapping and staggered start-up times allow for cross-fertilization of physics results
- ❖ Temporal gap between in HEP colliders (HL-LHC / FCC) allows for a balanced effort between different colliders
 - Scientists can analyze LHC data while preparing for EIC
 - Scientists (especially early career) can research at EIC while preparing for FCC

The ePIC Detector

❖ ePIC is an ambitious detector that uses several cutting-edge technologies

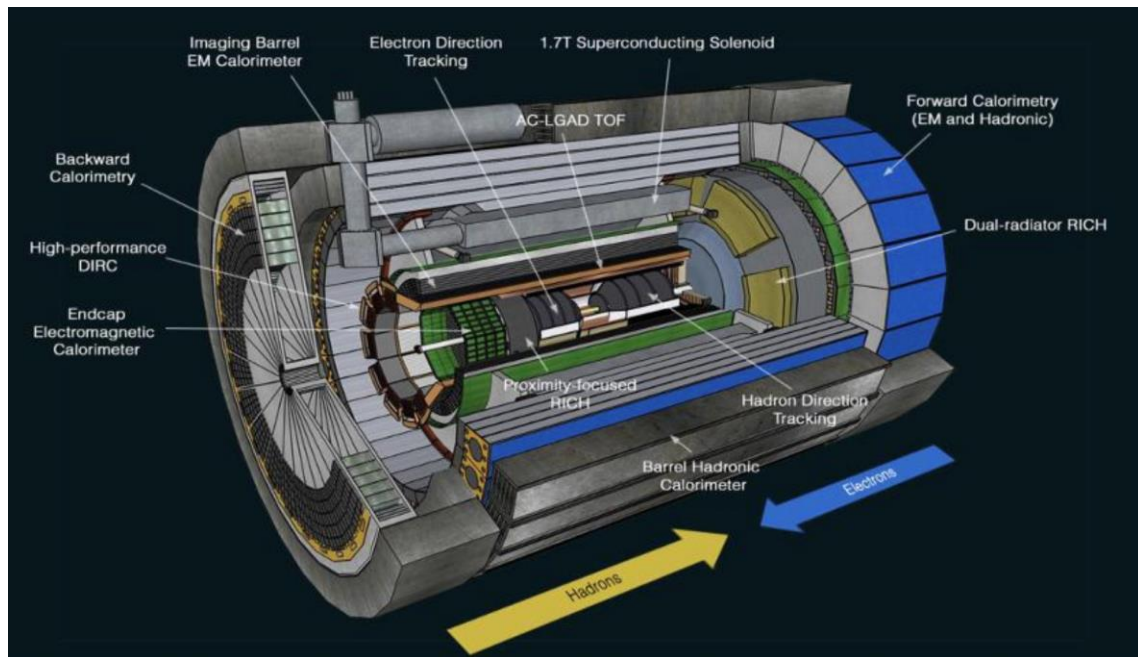

- Asymmetric beams and energies require **asymmetric detectors** with electron and hadron endcaps
- **Tracking, Particle Identification, EM & HAD Calorimeters** with large coverage $|\eta| < 4$
- **Magnet** for precision tracking
- **Streaming electronic readout**

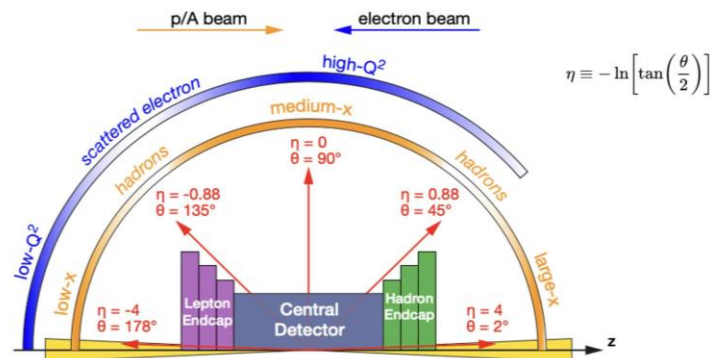

The ePIC Detector

- ❖ ePIC Detector: 26 subsystems over ± 40 m to measure particle momenta, energy and particle type

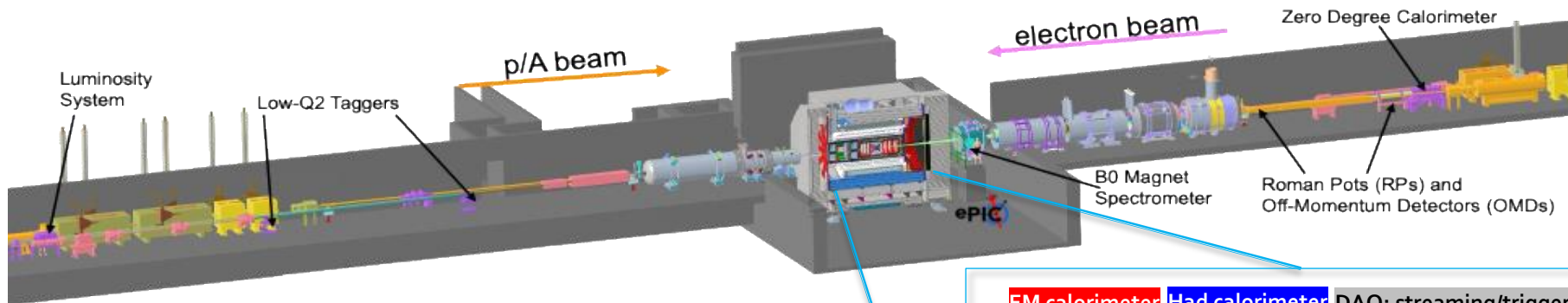

- 3 Electromagnetic calorimeters
- 3 Hadronic calorimeters
- Tracking: Silicon and Multi-pattern gas detectors
- Particle Identification: 3 RICH detector and Time-of-Flight
- 7 Auxiliary detectors (Si, HCal, EMCals)
- Electron and Hadron Polarimetry
- Streaming Readout

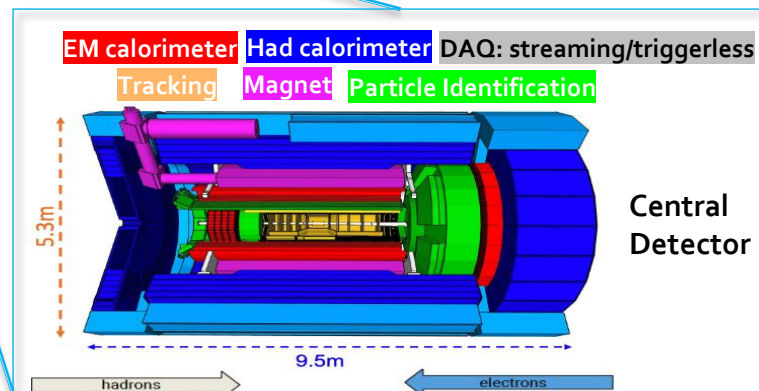

Computing and Data Analysis

❖ Streaming Readout and DAQ

- High-speed data flow and zero dead time

❖ Streaming Computing Model

- Continuous calibration and alignment enables rapid delivery of scientific results.
- Resources organization across the computing hierarchy

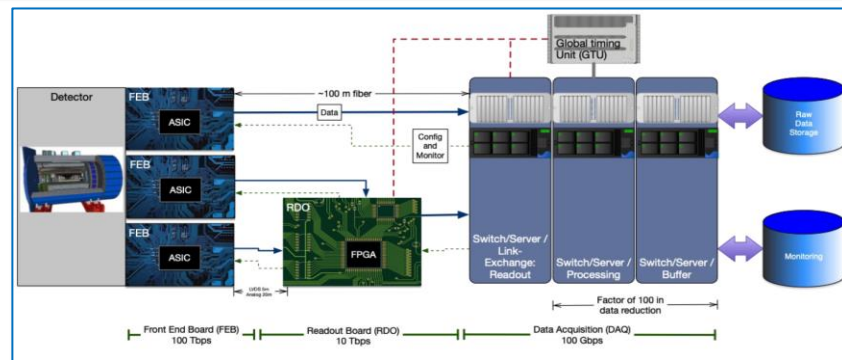

❖ AI/ML will be integrated into virtually every facet of the data processing pipelines of HEP/NP experiments

- EIC is being designed during the AI revolution and can take advantage of AI/ML since the design and R&D phase
- EIC may be the first large-scale detector optimized with machine learning.



[AI4EIC workshop](#)

AI/ML opportunities:

- **Adaptive Experimentation / AI-assisted Optimizations**
- **"Holistic" analysis:** full event information, and real-data
 - Simulations, Intelligent Data filtering, Particle Reconstruction and Identification (Calorimeters, Tracking, PID, Jets), Rapid Detector Diagnostics and Optimization, with systems capable of automatically Calibrating Detectors and Validating Data
- **Uncertainty Quantification** (event-level) and **Unfolding with Uncertainty**
- **Towards near Real-Time applications** (supported by Streaming Readout)

Cross-fertilization - MAPS

Monolithic Active Pixel Sensors (MAPS)

- **Low mass:** combine readout circuitry and sensing elements in a single and compact silicon device
- **Commercial foundries** can be used
- **Cost savings**, i.e. in bump-bonding, cooling
- New MAPS process technology, e.g. 28 nm



First MAPS deployment was in the STAR exp. at RHIC

Cross-fertilization - MAPS

Monolithic Active Pixel Sensors (MAPS)

- **Low mass:** combine readout circuitry and sensing elements in a single and compact device
- **Commercial foundries** can be used
- **Cost savings**, i.e. in bump-bonding, cooling
- New MAPS process technology, e.g. 28 nm



First MAPS deployment was in the STAR exp. at RHIC

- ❖ MAPS were further developed for LHC upgrades (see **ALICE ITS₃**) and EIC (**ePIC SVT**)
- ❖ **All detector concepts for a Higgs Factory (e.g. FCC-ee) have MAPS vertex detector** (very similar requirements as at EIC)

❖ LHC's ALICE ITS₃ for ultra-light Tracking



- Reduce **material thickness**
Remove electrical substrate, mechanical support, and active cooling (air cooling) in detector acceptance
 - **MOSAIX device bent to the target radii** (Layer-0 as small as 19 mm)
 - Mechanically in place by carbon foam ribs

MOSAIX device

- Tower Jazz 65nm technology
- 50 μm thickness
- Stitching to create a wafer-scale chip of $26.6 \times 1.95 \text{ cm}^2$
- Pixel size $22.8 \times 20.8 \mu\text{m}$ pixel size
- In-pixel front end electronics
- Time resolution 0.1-2 μsec
- Power consumption $<40 \text{ mW/cm}^2$

❖ ePIC Silicon Vertex Tracker (SVT) is the innermost subsystem of the central detector and is based on ALICE ITS₃ design

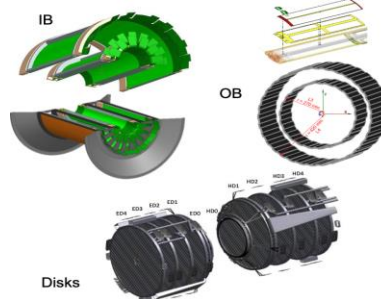

- **Barrel**
 - Inner Barrel: *curved, thinned* **MOSAIX** device
 - Outer Barrel: Large Area Sensor (LAS) derived from **MOSAIX** with a focus on large-area coverage in layers and disks
- **Endcap**
 - 5 Hadron Disk and 5 Lepton Disks (LAS Sensors)
- **Overall dimensions radius ~ 0.4 m, length ~ 2.2 m**

Cross-fertilization - LGADs

High electric field causes impact ionization by electrons in Silicon

- Gain (10x-100x)
- Fast-timing (~30 ps resolution)
- 1.3x1.3 mm² pads

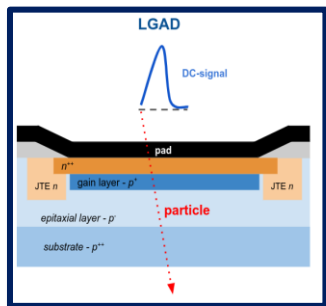

- **Low Gain Avalanche Diode (LGAD) R&D** has had an explosion of interest in the last ~10 years since its first adoption by ATLAS and CMS for HL-LHC
 - Pileup suppression
- **Many different LGAD technologies** are being investigated
 - Focusing on different challenges: radiation hardness, fill factor, timing, pixelation, photon detection
- **Several foundries** in China, Europe, US and Japan

ATLAS High Granularity Timing Detector (HGTD)

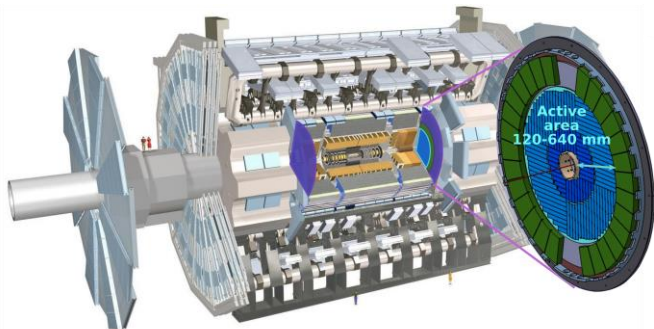

CMS Endcap Timing Layer (ETL)

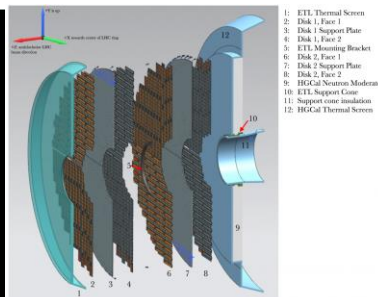
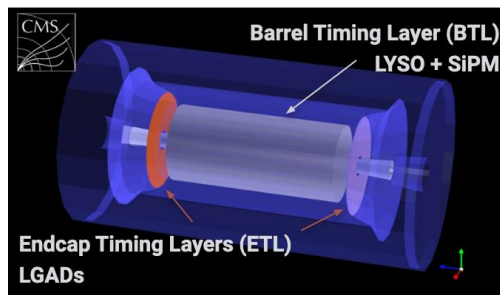

Cross-fertilization - LGADs

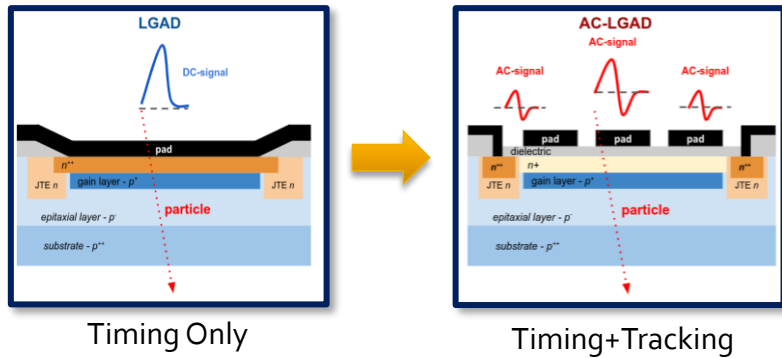

❖ The ePIC detector at the EIC

- 4D tracking and Particle identification with Time-of-Flight (TOF)
 - $e/\pi/K/p$ at low/intermediate momentum
 - Good time resolution is needed
 - Barrel, end-cap and far-forward (luminosity Monitor, B-o, Roman Pots)
- TOF layers based on AC-LGAD technology: Strips and Pixels

❖ AC-LGAD:

- Time-of-Flight detectors to cover PID at low momentum
- Also provide spatial info for tracking
- Resolution: ~ 30 ps, $30 \mu\text{m}$ (with charge sharing)

- First deployment of AC-LGADs
- Largest AC-LGADs ever produced

HPK wafer production

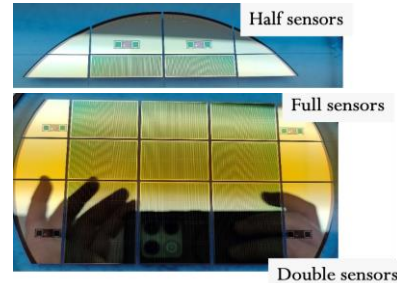

❖ Strips:

- Sensor size: $3.2 \times 2.2 \text{ cm}^2$
- Strips: 1 cm long, width $40\text{-}50 \mu\text{m}$, pitch $500 \mu\text{m}$

HPK wafer production

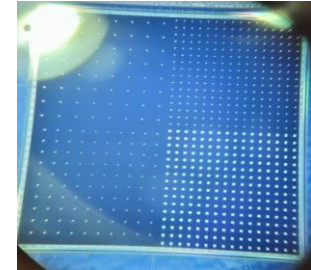

❖ Pixels:

- Sensor size: $1.6 \times 1.6 \text{ cm}^2$
- Pixels: pitch $500 \mu\text{m}$

Cross-fertilization – Detector Readout

- ❖ Evolution of readout ASICs from LHC to EIC, which in turn will benefit future experiments

ALTIROC

for ATLAS HGTD
(for LGAD sensor)

ETROC

for CMS ETL
(for LGAD sensor)

HGCROC

for CMS HGCal
(for Silicon Sensor)

Cross-fertilization – Detector Readout

❖ Evolution of readout ASICs from LHC to EIC, which in turn will benefit future experiments

ALTIROC
for ATLAS HGTD
(for LGAD sensor)



EICROC
for ePIC *Pixel* TOF
(AC-LGAD sensor)

ETROC
for CMS ETL
(for LGAD sensor)



FCFD
for ePIC *Strip* TOF
(AC-LGAD sensor)

HGCROC
for CMS HGCAL
(for Silicon Sensor)



CaloRoc
for ePIC *calorimeter*
(for SiPMs readout)

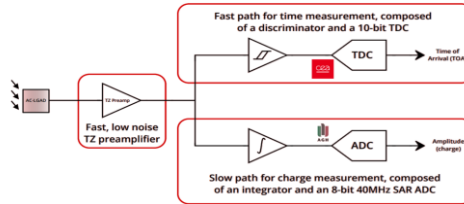

- 130 nm CMOS
- $500 \times 500 \mu\text{m}^2$ pixels
- ~ 30 ps time resolution
- Low power $\sim 1\text{mW}/\text{ch}$
- Use signal sharing in AC-LGAD: TDC data and 8 ADC values

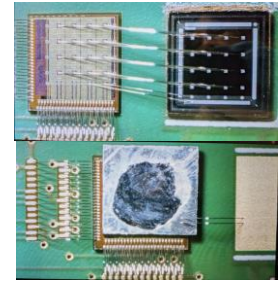

Reference presentation

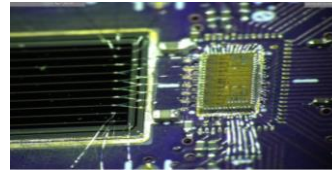

- 65 nm CMOS
- $0.5 \text{ mm} \times 1 \text{ cm}$ strips
- Constant Fraction Discriminate (CFD) in chip

[Reference presentation](#)

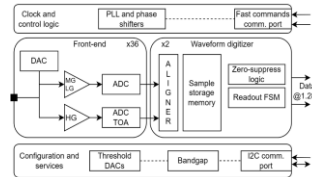

- **Charge and Time on a large Dynamic Range**
- 20 ps and < 500 ps for a MIP
- Low power
- Same ASIC structure (floorplan), ADC and TDC, readout, interfaces as HGCROC



HGCROC

Reference presentation

A Global R&D

❖ HEP-NP synergies are strong given the phasing of physics projects and the overlap in physics drivers

- Several technologies originated in HEP and were adopted and advanced at EIC with significant innovations
- Some technologies are driven by the EIC project given that HEP projects are farther in the future

❖ Accelerator and Detector R&D at ePIC will in turn benefit HEP experiments, e.g. LHC and FCC

- Several strategic goals for R&D are common between CERN and US and mostly common between HEP and NP, with overlapping of efforts (see [DOE Basic Research need – BRN 2019](#), [CERN's DRD Collaborations](#) and [CPAD's RDC](#))

❖ Synergies with HL-LHC and FCC in accelerators:

- Crab Cavities, Beam properties
- Superconducting Magnets and Superconductive Radio Frequency Cavities
- Machine Detector Interfaces, Synchrotron Radiation simulations

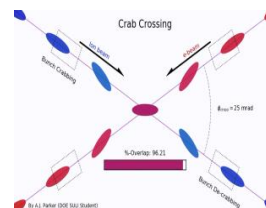

❖ FCC-ee detectors (e.g. ALLEGRO)

- Vertex Detector: **MAPS** - possibly like ALICE 3 / ePIC
- **TOF for Particle Flow and Particle Identification:** flavor physics, $H \rightarrow ss \dots$
 - Silicon Wrapper + ToF: **AC-LGAD** or **MAPS**

❖ Streaming readout can become a standard in next generation of colliders:

- A triggerless streaming architecture gives much more flexibility to do physics (max data preservation, diverse topologies)

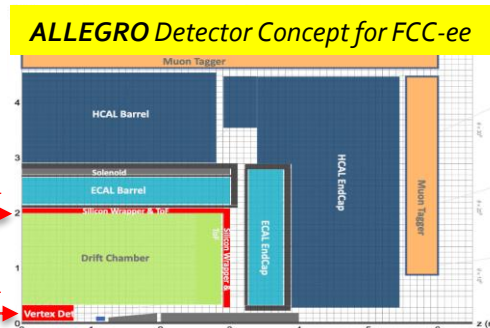

Silicon Wrapper
+ TOF

Vertex Detector

Deep Inelastic Scattering (DIS) at EIC

Salvatore Fazio

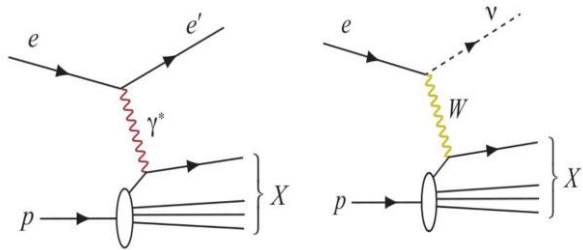
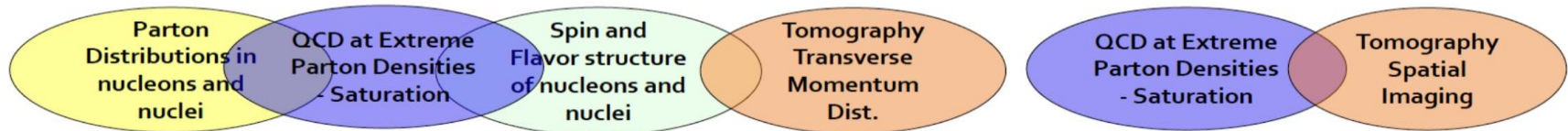

NC & CC Inclusive DIS

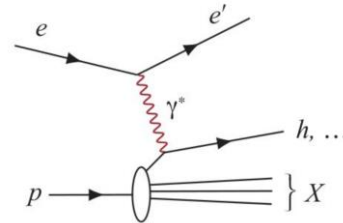

Semi-Inclusive DIS

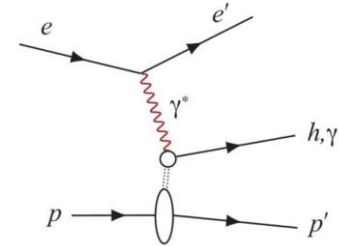

Exclusive Reactions

$\int \mathcal{L} dt:$

$\sim 1 \text{ fb}^{-1}$

$\sim 10 \text{ fb}^{-1}$

$\sim 100 \text{ fb}^{-1}$

Strong Interactions at EIC...and LHC

- ❖ **The LHC is mostly a 'gluon collider'** as most processes originate from gluon interactions
 - The understanding of quark and gluon composition in the proton (**Parton Distribution Function - PDF**) is critical for precision measurements and searches for new physics
- ❖ **Understanding strong interactions** (hard and soft QCD) is critical for the success of the LHC program, and is one of the goals of the LHC program itself as well as of future particle physics colliders
 - e.g. measurements of **jet production and substructure**, $\alpha_s(Q^2)$, **Multi-Parton Interactions (MPI)** in jet, top-quark and vector boson productions, and in heavy-ion program at the LHC

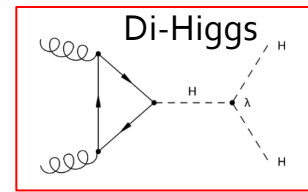
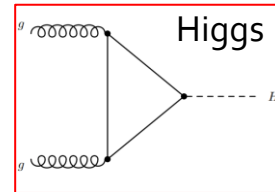
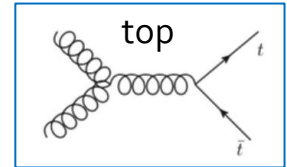
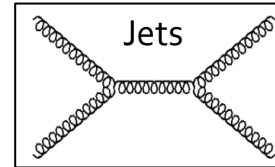

Strong Interactions at EIC...and LHC

- ❖ **The LHC is mostly a 'gluon collider'** as most processes originate from gluon interactions
 - The understanding of quark and gluon composition in the proton (**Parton Distribution Function - PDF**) is critical for precision measurements and searches for new physics
- ❖ **Understanding strong interactions** (hard and soft QCD) is critical for the success of the LHC program, and is one of the goals of the LHC program itself as well as of future particle physics colliders
 - e.g. measurements of **jet production and substructure**, $\alpha_s(Q^2)$, **Multi-Parton Interactions (MPI)** in jet, top-quark and vector boson productions, and in heavy-ion program at the LHC

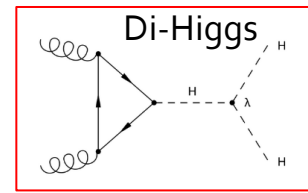
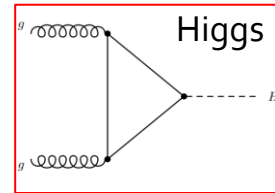
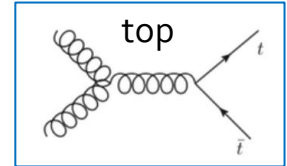
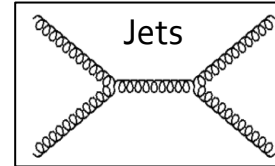

- **The EIC will probe the quark and gluon structure of nucleons and nuclei**, thanks to a simple and well-known probe: the electron
 - Complementary measurements to LHC and FCC, and in turn they will benefit the LHC and FCC physics programs

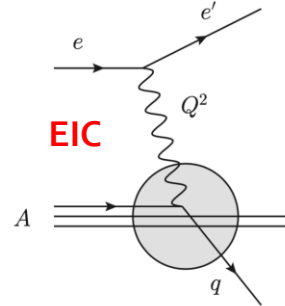

Strong Interactions at EIC...and LHC

- ❖ **The LHC is mostly a 'gluon collider'** as most processes originate from gluon interactions
 - The understanding of quark and gluon composition in the proton (**Parton Distribution Function - PDF**) is critical for precision measurements and searches for new physics
- ❖ **Understanding strong interactions** (hard and soft QCD) is critical for the success of the LHC program, and is one of the goals of the LHC program itself as well as of future particle physics colliders
 - e.g. measurements of **jet production and substructure**, $\alpha_s(Q^2)$, **Multi-Parton Interactions (MPI)** in jet, top-quark and vector boson productions, and in heavy-ion program at the LHC

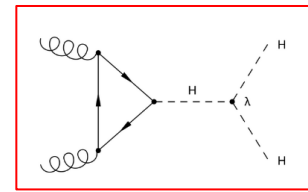
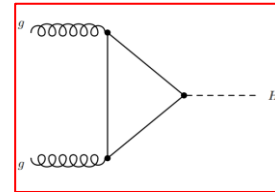
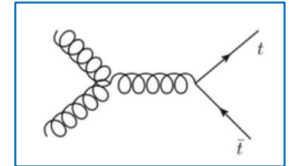
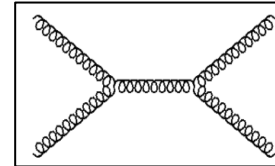

- **The EIC will probe the quark and gluon structure of nucleons and nuclei**, thanks to a simple and well-known probe: the electron
 - **Complementary measurements to LHC and FCC, and in turn they will benefit the LHC and FCC physics programs**

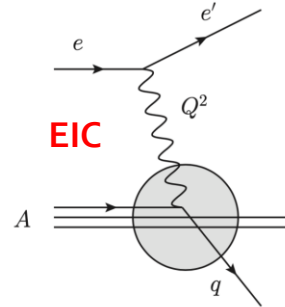

The QCD Program at EIC

1. Three-dimensional structure of nucleons and nuclei in momentum and configuration space
2. The flavor and spin structure of the proton
3. QCD in nuclei
4. Fundamental parameters: α_s

1. Nucleon Structures at EIC and LHC

The Nucleon's Quark and Gluon structure is expressed as Parton Distributions with various levels of details and sophistication

- **Parton Distribution Funct. (PDFs):** collinear (i.e. transverse-momentum integrated) functions that describe the proton content vs the longitudinal momentum fraction (x)
- **Transverse Momentum Dependent PDFs (TMD):** 3-D momentum distribution
- **Generalized Parton Distributions (GPDs):** probe also transverse spatial distribution
- ➔ **PDFs, TMDs, and GPDs provide complementary information and a more complete picture of how nucleons are composed at the level of quarks and gluons**

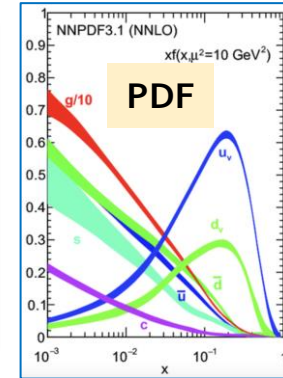

1. Nucleon Structures at EIC and LHC

The Nucleon's Quark and Gluon structure is expressed as Parton Distributions with various levels of details and sophistication

- **Parton Distribution Funct. (PDFs):** collinear (i.e. transverse-momentum integrated) functions that describe the proton content vs the longitudinal momentum fraction (x)
- **Transverse Momentum Dependent PDFs (TMD):** 3-D momentum distribution
- **Generalized Parton Distributions (GPDs):** probe also transverse spatial distribution
- ➔ **PDFs, TMDs, and GPDs provide complementary information and a more complete picture of how nucleons are composed at the level of quarks and gluons**

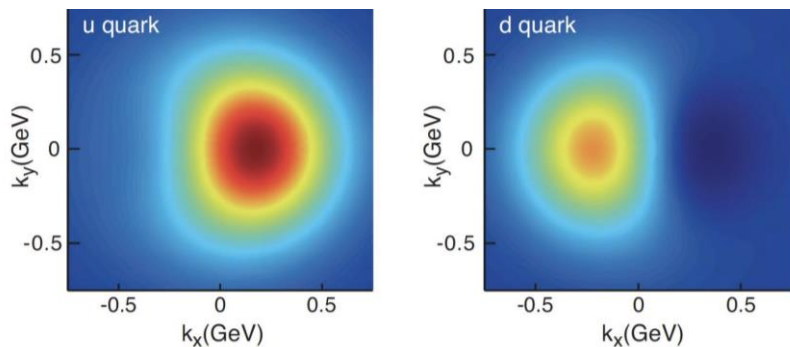
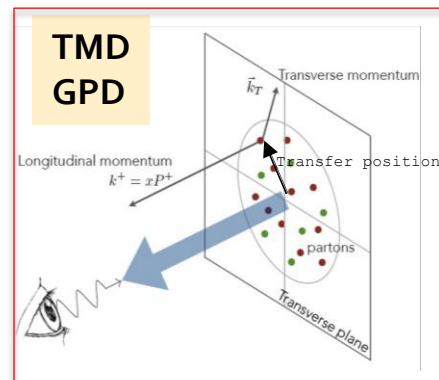
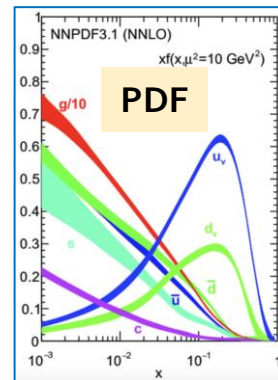

Spin-dependent 3-D Transverse momentum distributions

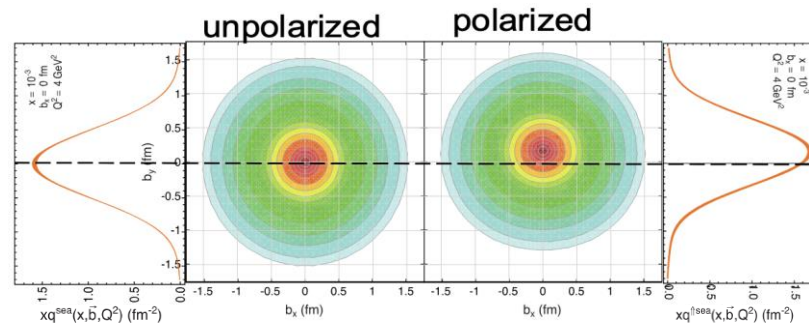

Spin dependent 2-D Transverse position distributions

1. Nucleon Structures at EIC and LHC

➤ Open Questions that EIC aims to address:

- **Are TMDs universal?**
(see collinear PDFs)?
- **How do TMDs evolve in Q^2**
(see DGLAP evolution of collinear PDFs)?
- **How is the transition between TMD and collinear PDF?**



- Compare observables at EIC and LHC
study how p_T distributions of bosons, e.g. the Higgs, are affected by gluon-TMDs
- Test the limits of applicability and the transition to the collinear PDF formalism that applies at large p_T

- While GPDs have reached high level of theoretical sophistication, measurements are limited by low statistics for exclusive processes and detector coverage



- Impact on Multi-Parton Interaction (MPI) at the LHC
(independent hard scatters of colliding partons)

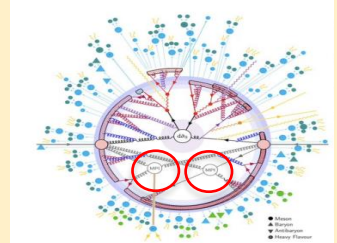

2. Flavor and Spin at EIC and LHC

❖ The energy reach of many Beyond-SM (BSM) searches at the HL-LHC depends on PDFs

- At masses \gg TeV, BSM particle production requires *large-x*, where PDF uncertainties are large
→ Forward particle production at LHC and DIS at EIC can constrain PDFs at large-x

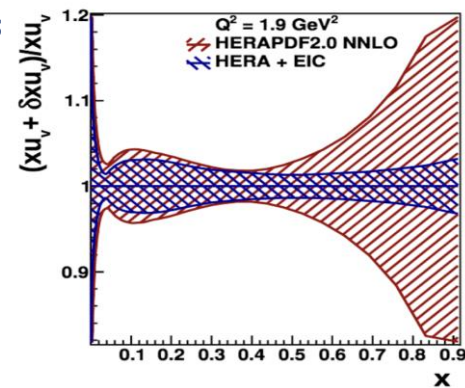

2. Flavor and Spin at EIC and LHC

❖ The energy reach of many Beyond-SM (BSM) searches at the HL-LHC depends on PDFs

- At masses \gg TeV, BSM particle production requires *large-x*, where PDF uncertainties are large
→ Forward particle production at LHC and DIS at EIC can constrain PDFs at large-x

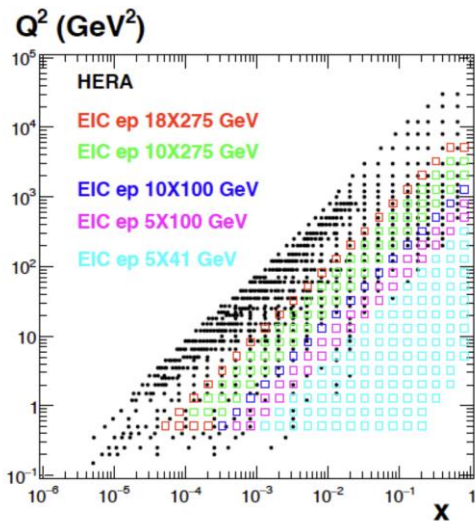

❖ For Hadron Colliders (LHC) it is important to constrain PDFs at large-x over a *wide* Q^2

- Production rate of new heavy particles as well as W and Z bosons or jet production at high p_T are affected

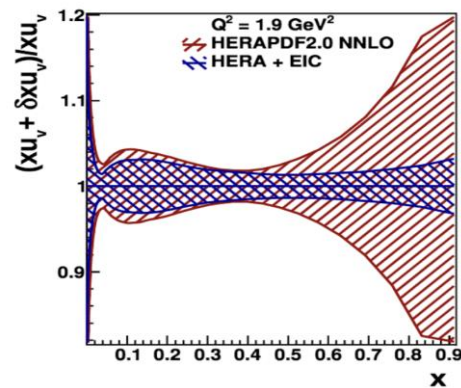

2. Flavor and Spin at EIC and LHC

❖ The energy reach of many Beyond-SM (BSM) searches at the HL-LHC depends on PDFs

- At masses \gg TeV, BSM particle production requires *large-x*, where PDF uncertainties are large
 → Forward particle production at LHC and DIS at EIC can constrain PDFs at large-x

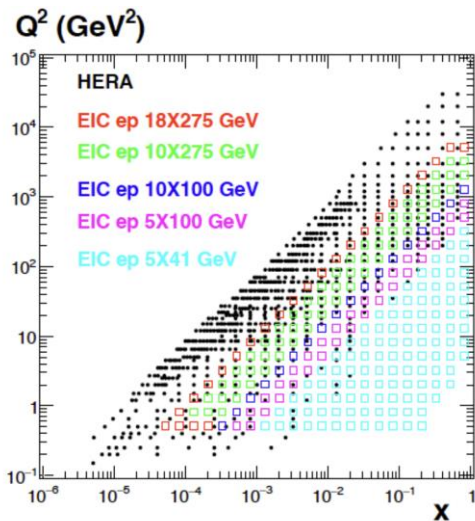

❖ For Hadron Colliders (LHC) it is important to constrain PDFs at large-x over a *wide* Q^2

- Production rate of new heavy particles as well as W and Z bosons or jet production at high p_T are affected

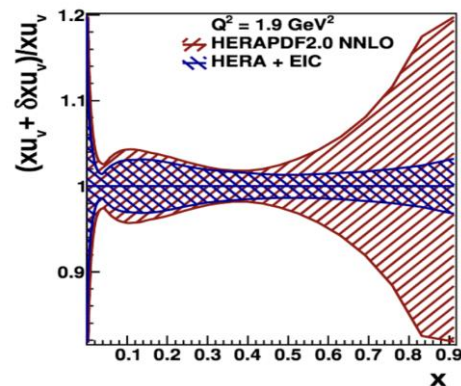
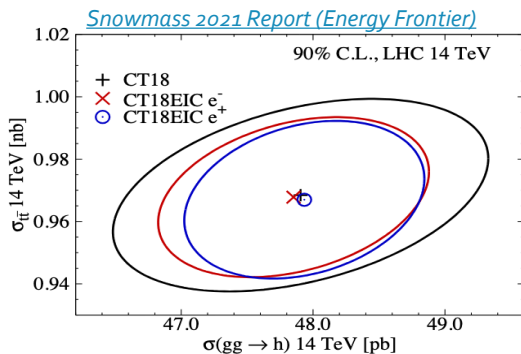

❖ EIC will constrain the PDFs for LHC for high-mass BSM searches with small systematics and BSM-free

- The ability of LHC measurements to reduce the PDF uncertainty depends on the control of systematic effects

3. QCD in Nuclei at EIC and LHC

❖ EIC will be the first collider that allows deep inelastic scattering with Nuclei

- Study internal structure of heavy ions, complementary to the heavy-ion program at the LHC
- EIC will reduce the large uncertainty of Nuclear PDFs at *small-x*
 - Impact on jets as they pass through deconfined QCD matter at the LHC in heavy-ion collisions

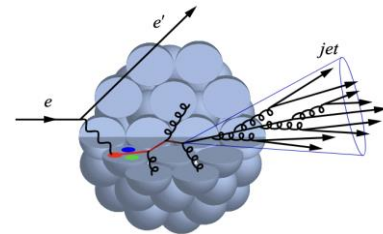

3. QCD in Nuclei at EIC and LHC

❖ EIC will be the first collider that allows deep inelastic scattering with Nuclei

→ Study internal structure of heavy ions, complementary to the heavy-ion program at the LHC

→ EIC will reduce the large uncertainty of Nuclear PDFs at *small-x*

- Impact on jets as they pass through deconfined QCD matter at the LHC in heavy-ion collisions

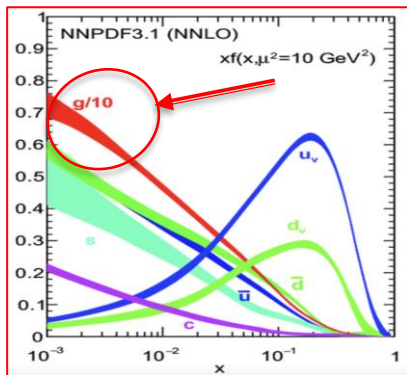
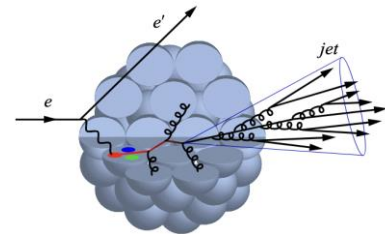

❖ At high collision energies (i.e. *small-x*), soft gluon emission is very large. To preserve unitarity gluon merging is predicted, leading to gluon saturation

- Gluon saturation is accessible in DIS experiments at lower energies with nuclei than with protons



❖ EIC will study the Initial Conditions for Quark-Gluon Plasma: *small-x* probes the starting point for a system to evolve towards a deconfined QCD matter

- To understand elliptic flow and the ridge effects at the LHC, interpreted as multi-particle *correlations* either already present in the colliding protons/nuclei or, alternatively, generated by *collective interactions* when QCD matter is deconfined

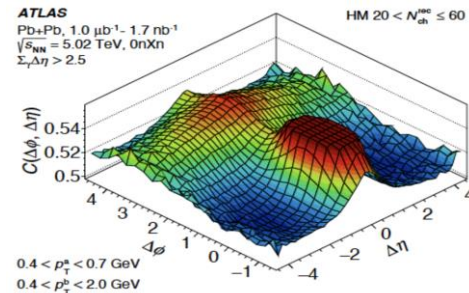

4. Strong Coupling α_s

❖ Two main goals for α_s measurements:

1. Measure the running of $\alpha_s(Q)$ up to the highest scales possible
→ Hadron Colliders
2. Measure $\alpha_s(M_Z)$ as precisely as possible
→ Find phase space with small uncertainties (ep, e^+e^-)

[Snowmass 2021](#)

Method	Relative $\alpha_s(m_Z)$ uncertainty	
	Current	Near (long-term) future
(1) Lattice	0.7%	$\approx 0.3\%$ (0.1%)
(2) τ decays	1.6%	$< 1\%$
(3) $Q\bar{Q}$ bound states	3.3%	$\approx 1.5\%$
(4) DIS & global PDF fits	1.7%	$\approx 1\%$ (0.2%)
(5) e^+e^- jets & evt shapes	2.6%	$\approx 1.5\%$ ($< 1\%$)
(6) Electroweak fits	2.3%	$(\approx 0.1\%)$
(7) Standalone hadron collider observables	2.4%	$\approx 1.5\%$
World average	0.8%	$\approx 0.4\%$ (0.1%)

- ## ❖ The EIC will provide new high-luminosity data that could lead to a percent uncertainty level on α_s

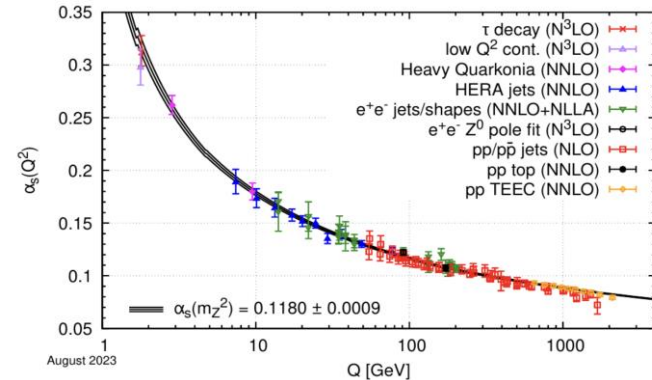

[Snowmass 2021](#)

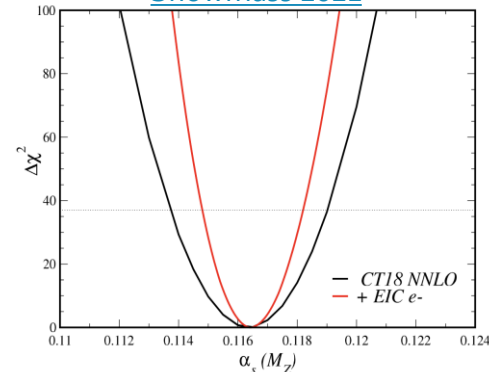

New Opportunities

❖ Jet substructure will be used to probe cold nuclear matter and hadronisation in eA and ep collisions at EIC

- *Time evolution* from the hard collision evolving into parton-shower and eventually into color-neutral hadrons (fragmentation, hadronization)
- Jet substructure exploits info on *internal radiation patterns*: key role at the LHC

❖ Testing Entanglement in DIS at the EIC

- Evidence of *quark-gluon entanglement* inside a proton at small- x : system retains initial quantum state information after hadronization and formation of jets
 - Maximal entanglement predicts relation between the *jet* fragmentation function and the entropy of hadrons produced in jet fragmentation (related to # of produced charged hadrons)
- **Complementarity with LHC studies**

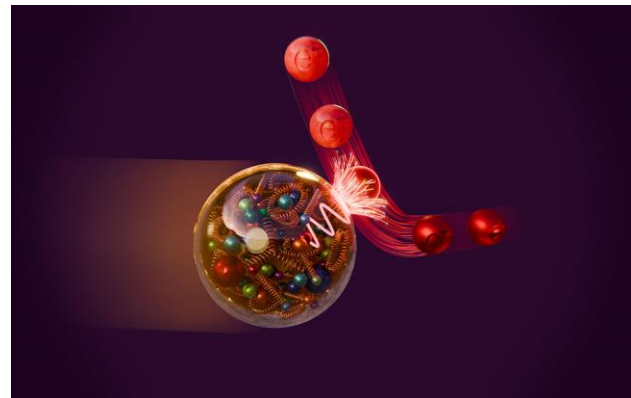
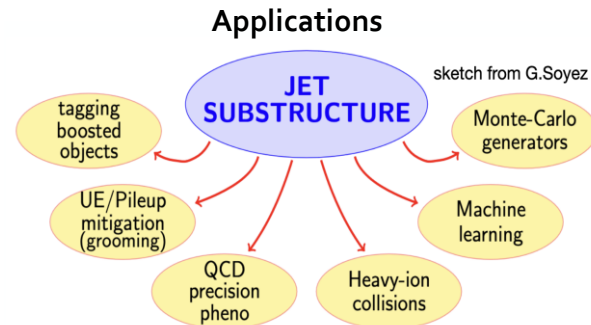

Electroweak Interactions at EIC

❖ The weak mixing angle θ_W is a fundamental parameter of the SM

- It governs the mechanism of *spontaneous symmetry breaking* of $SU(2) \times U(1)$ in which the original vector boson fields W and B^0 are transformed to the physical W^\pm , Z , and γ states
- θ_W and M_W are tightly correlated in the SM, so that experimental improvements in either one might challenge the validity of the SM and provide **hints of New Physics at yet unprobed energy scales**

$$\begin{pmatrix} \gamma \\ Z^0 \end{pmatrix} = \begin{pmatrix} \cos \theta_W & \sin \theta_W \\ -\sin \theta_W & \cos \theta_W \end{pmatrix} \begin{pmatrix} B^0 \\ W^0 \end{pmatrix} \quad \sin^2 \theta_W = 1 - \frac{M_W^2}{M_Z^2}$$

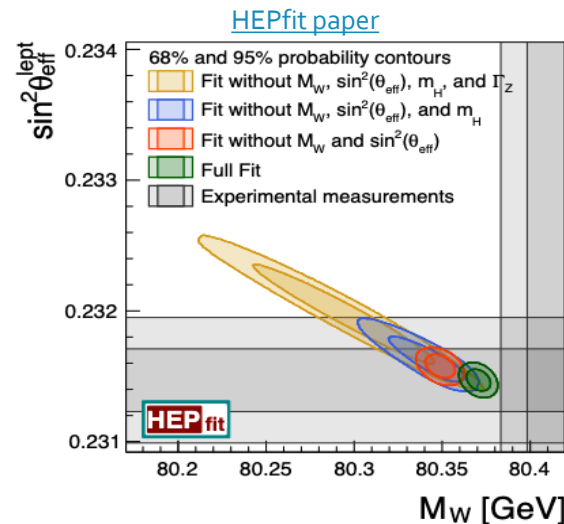

Electroweak Interactions at EIC

❖ The weak mixing angle θ_W is a fundamental parameter of the SM

- It governs the mechanism of *spontaneous symmetry breaking* of $SU(2) \times U(1)$ in which the original vector boson fields W and B^0 are transformed to the physical W^\pm , Z , and γ states
- θ_W and M_W are tightly correlated in the SM, so that experimental improvements in either one might challenge the validity of the SM and provide **hints of New Physics at yet unprobed energy scales**

$$\begin{pmatrix} \gamma \\ Z^0 \end{pmatrix} = \begin{pmatrix} \cos \theta_w & \sin \theta_w \\ -\sin \theta_w & \cos \theta_w \end{pmatrix} \begin{pmatrix} B^0 \\ W^0 \end{pmatrix} \quad \sin^2 \theta_w = 1 - \frac{M_W^2}{M_Z^2}$$

Davoudiasl et al. *Phys. Rev. D* 108, 115018;
Boughezal et al., 2204.07557

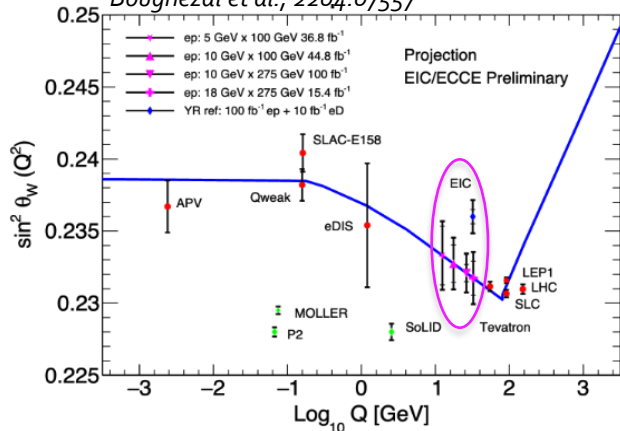

- ❖ $\sin^2 \theta_W$ may be extracted at EIC by comparing right-handed and left-handed electron scattering at different energies

- ❖ The EIC can fill the gap in weak-mixing angle measurements between low-energy probes and high-energy colliders
➔ **Test of scale dependence**

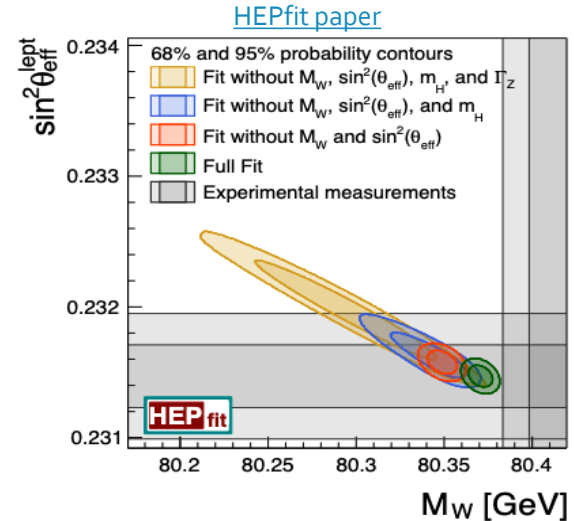

Electroweak and BSM Physics at EIC

❖ Indirect constraints to New Physics via Effective Field Theory (EFT):

- The SM can be considered as an effective low-energy approximation of a more complete but unknown theory

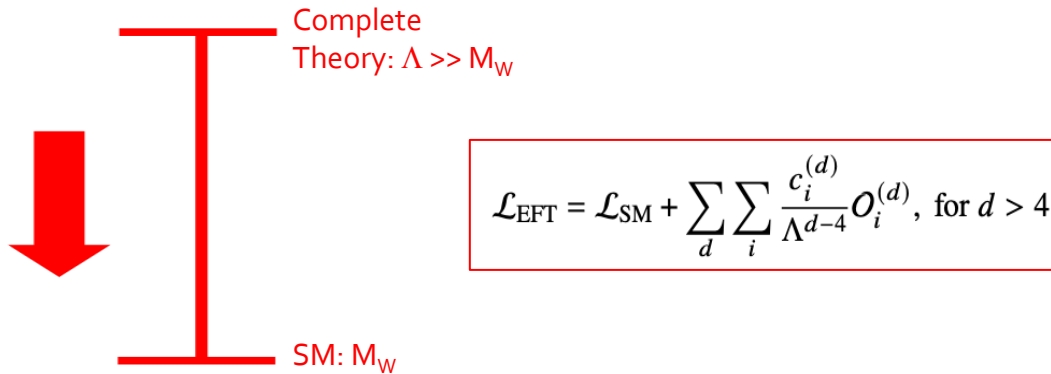

Electroweak and BSM Physics at EIC

❖ Indirect constraints to New Physics via Effective Field Theory (EFT):

- The SM can be considered as an effective low-energy approximation of a more complete but unknown theory
- New processes enter at loop level and produce *anomalous couplings*

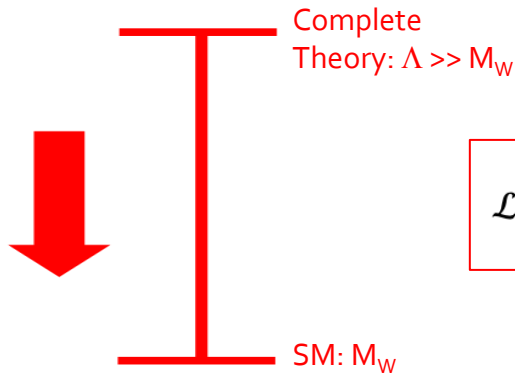

$$\mathcal{L}_{\text{EFT}} = \mathcal{L}_{\text{SM}} + \sum_d \sum_i \frac{c_i^{(d)}}{\Lambda^{d-4}} \mathcal{O}_i^{(d)}, \text{ for } d > 4$$

- For heavy new physics, the EFT provides a consistent framework to describe deviations from the SM

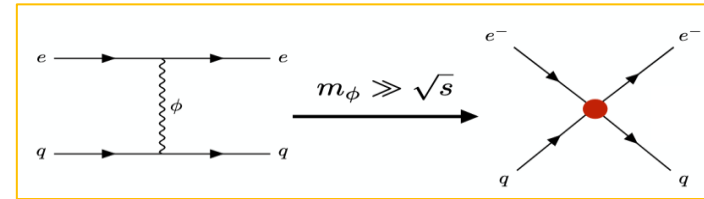
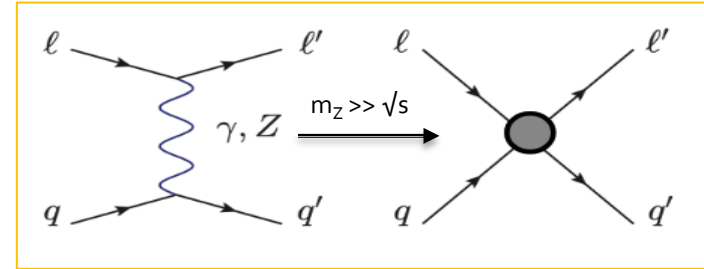

Electroweak and BSM Physics at EIC

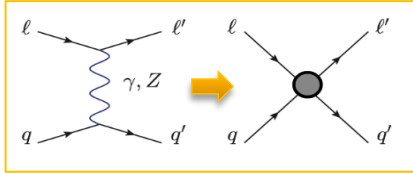

❖ EFT operators contribute to DIS processes

- Polarized DIS cross sections depend on quark, lepton polarizations, and probe different combinations of operators depending on beam polarizations

Boughezal, Petriello, Wiigand '20

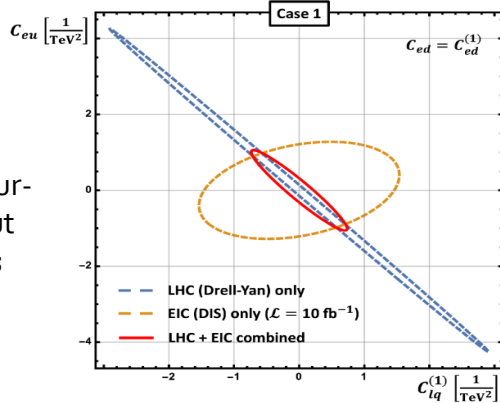

- Drell-Yan at the LHC provides strong constraints on EFT four-fermion operators, but can be **flat-directions**

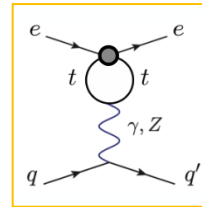

- EFT four-fermion operators involving the **top-quark**

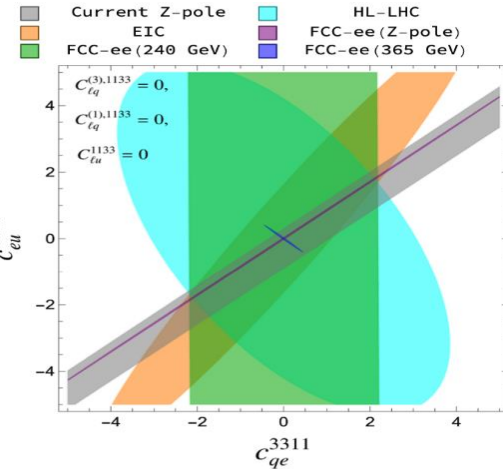

Bellafronte, Dawson, Giardino, Liu, 25, Jiang, Liu, Yan, 25

- ❖ Polarized DIS measurements at EIC can disentangle flat directions
- ❖ Complementary to LEP, LHC, and future high energy colliders

Direct BSM searches at EIC

❖ BSM can also be searched directly at EIC:

- Explore regions of phase space that are **not covered by other experiments**
- Characterize new physics candidates if some excess or deviations from the SM are found in other experiments

Different strategies depending on decays and lifetime of particle

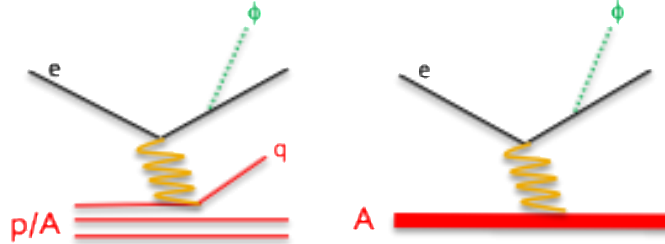
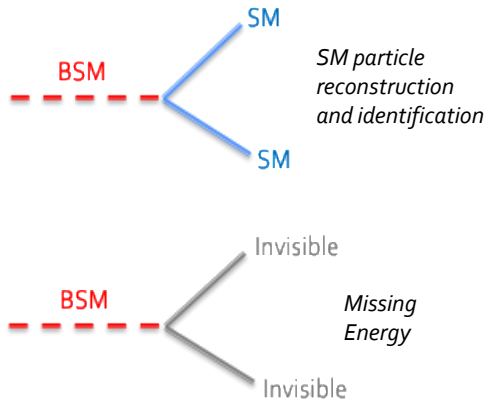

DIS
(ion breaks up)

Coherent scattering
(intact ion):

- Rate proportional to Z^2
(maximal for heavy ions:
6200/6700 for lead/gold)

BSM at EIC

- Clean, controlled initial and final states with precise kinematics
- Low Backgrounds
- Controlled Systematics
- High Luminosity
- Beam Polarization
- Far-forward and far-backward detectors
- Precise tracking, particle identification, flavor tagging, missing energy

➤ Ideal for **light and weakly coupled states** (Dark Photons, ALPs, HNLs, ...)

BSM searches at EIC – Lepton Flavor Violation

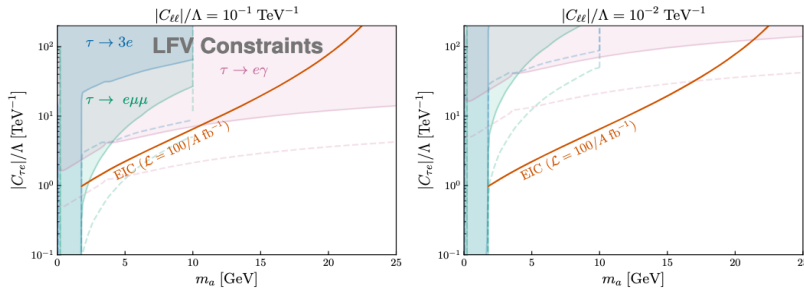
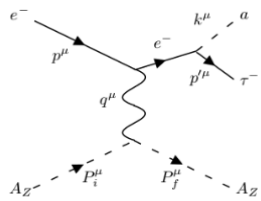
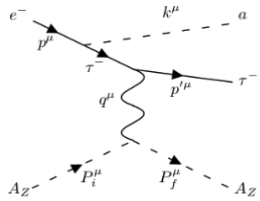

Davoudiasl, Marcarelli, Neil, 2112.04513, 2402.17821;
Cirigliano, Fuyuto, Lee, Mereghetti, Yan '21

- *Coherent scattering* can be exploited at EIC thanks to far-backward and far-forward detectors
- Light particle searches benefit from Z^2 enhancement in the production cross sections.

- ❖ EIC can search for charged lepton flavor violation
 - ePIC can disentangle *electron-to- τ transition*
 - competitive with other constraints from other facilities

❖ Leptoquarks (LQ)

- *High luminosity* (1000x HERA)
- Electron and positron beam will probe different types of LQs

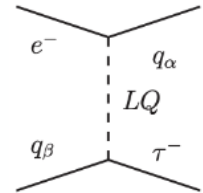

Gonderinger, Ramsey-Musolf, 1006.5063
Cirigliano, Fuyuto, Lee, Mereghetti, Yan '21

BSM searches at EIC – Long Lived Particles

❖ Axion-Like Particle searches

- Stringent bounds in both prompt-decay and displaced-vertex searches

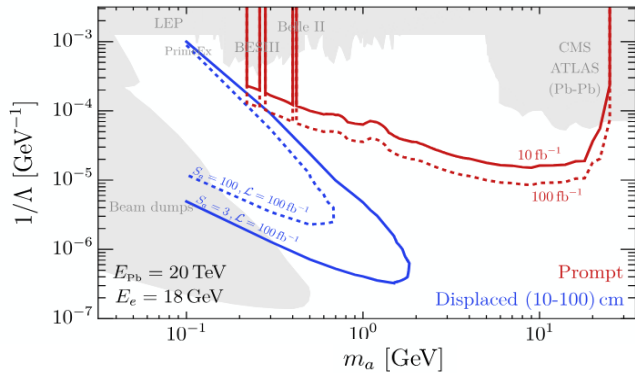
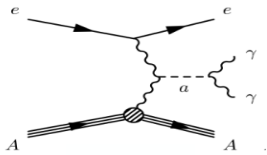

Balkin, Hen, Liu, Li, Ma, Soreq, Williams, 2310.08827; Liu, Yan '21

- ## ❖ Light Weakly interacting Vector Bosons
- from a variety of models can be discovered or constrained, over a broad parameter space, through displaced vertexing

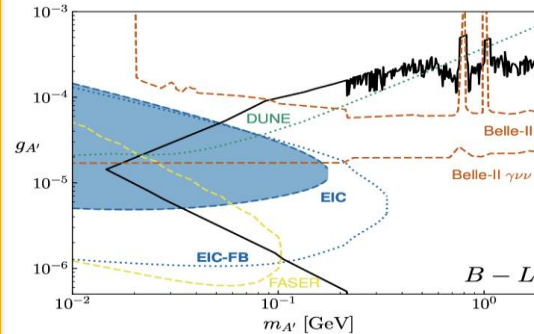
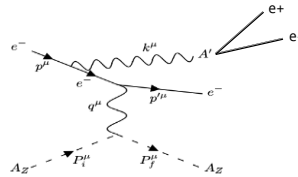

Davoudiasl, Marcarelli, Neil, 2307.00102

- ## ❖ Generic Scalar and Vector Dark Boson interactions with electrons and invisible particle

- Stringent and broad bounds

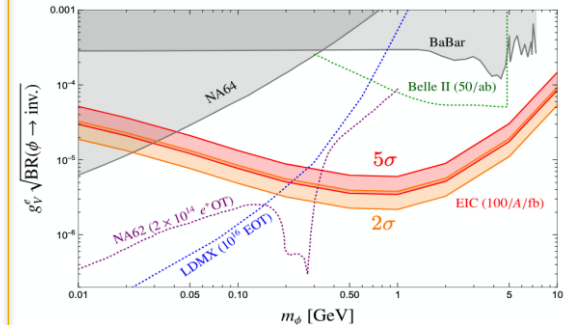
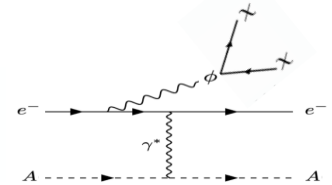

Davoudiasl, Liu, 2505.08871; Balkin, Coren, Jentsch, Liu, Ovchynnikov, Sore, Trifinopoulos, 2601.00068

The 2nd Detector - a blank canvas

- Details are not yet defined
- Users will have a significant impact on design and construction

[Reference presentation](#)

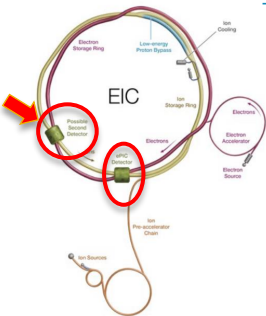

➤ Opportunities for new technologies:

- Muon spectrometer (to improve efficiency and purity)
- Higher magnetic field for better tracking resolution
- High-resolution barrel EM Calorimeter
- Improved Hadron Particle Identification in the barrel

➤ Physics Opportunities:

- Optimization for BSM, e.g. rare decays
- Expanded eA capabilities, e.g. with a 2nd Focus
 - Near-beam hadron detection
 - Enhanced capabilities for detection of light nuclei from coherent scattering

- ❖ Independent cross check of results and confirmation of discoveries
 - Requires a general-purpose detector supporting the full EIC science program
- ❖ Complementarity to ePIC
 - Combination of data from the two detectors can reduce the systematics
- ❖ New Physics Opportunities
 - Capitalize on new design ideas and detector technologies
- ❖ Must be cost-effective and built in a timely fashion

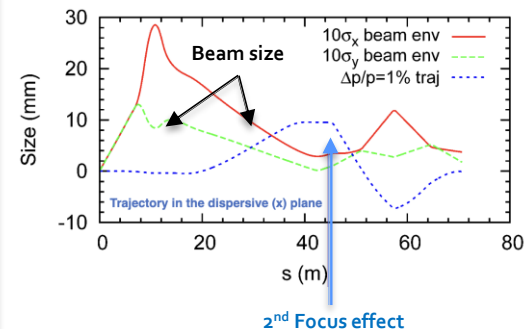

2nd Focus:

Make the beam small at the location where the transverse displacement of scattered particles is the greatest

Conclusions

"Nature does not distinguish 'Nuclear' vs. 'High Energy' physics" (Abhay Deshpande)

- ❖ **Strong overlap with HEP community interests in QCD, Electroweak and BSM physics**
 - PDF, proton spin and flavor, nuclear tomography, gluon saturation, α_s , jet substructure, entanglement etc.
 - Weak mixing angle, indirect (EFT) and direct (ALP, LFV, LQ, Dark Bosons etc.) searches for new physics
- ❖ **EIC is a complex and advanced machine**
 - Detectors and accelerator utilize many new technologies
 - Cross fertilization with LHC experiments
 - Much synergy with FCC-ee
 - Training ground for future accelerator and detector workforce
 - 2nd detector allows us to deploy new technologies, methods and can better accommodate BSM searches
- ❖ **HEP and Nuclear Physics communities are strongly engaged and well integrated** (boundaries are artificial)
- ❖ **Current studies only scratch the surface of future opportunities**
 - LHC has taught us that we typically outperform our predictions

Synergies, complementarities and opportunities for cross-fertilization between HEP and NP in physics studies, experimental technologies, analysis techniques, readout systems, and theoretical tools

Back-up

Back-up

Understanding the History of the Universe

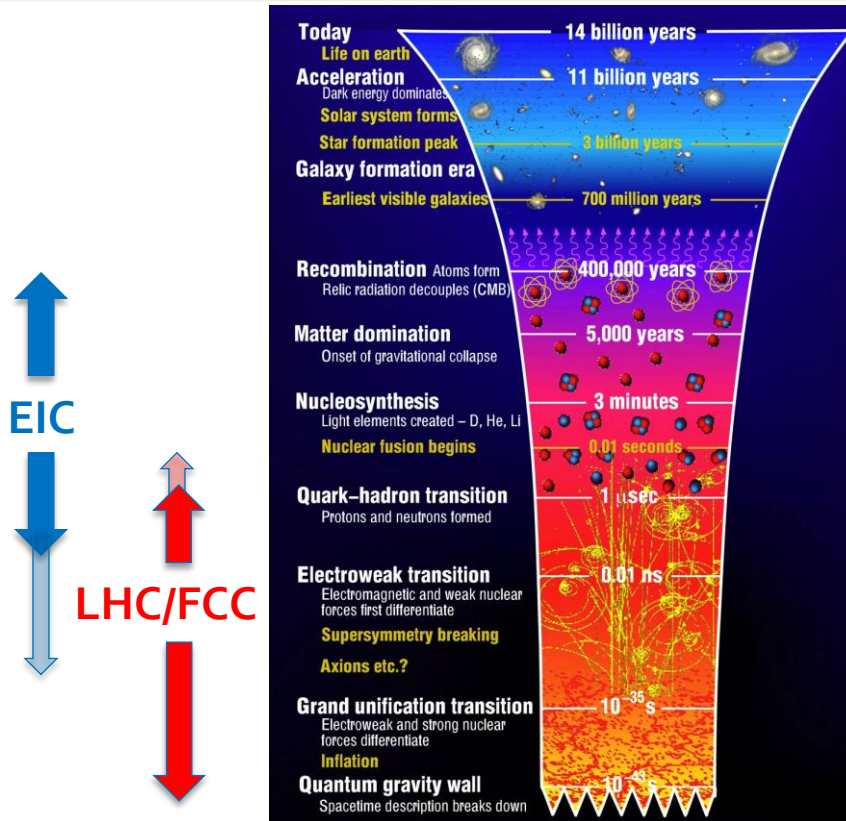

- Different accelerator facilities, colliding different particles with a common vision to understand the origin & emergence of the matter in universe

The EIC Program

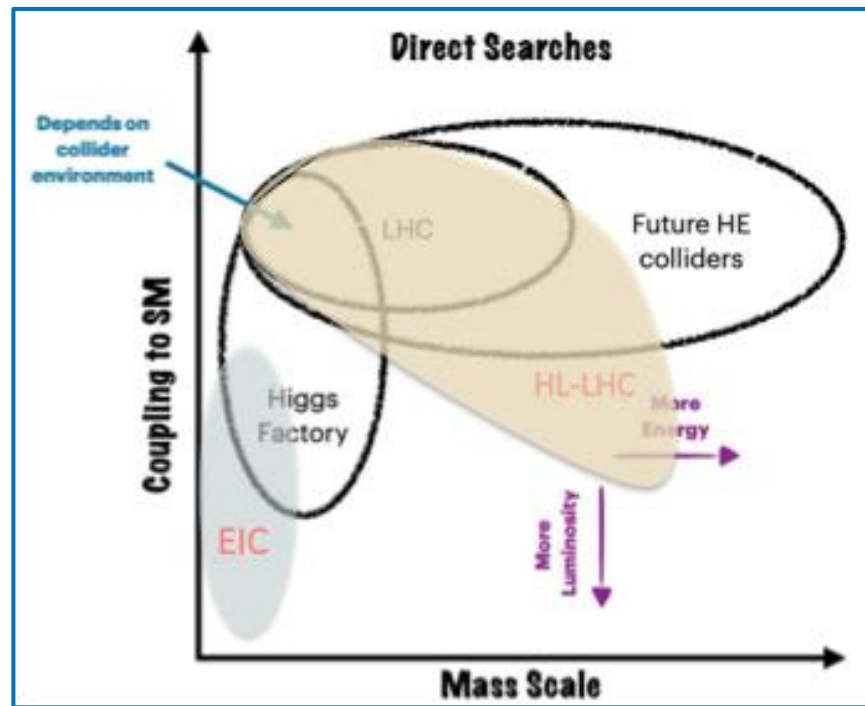
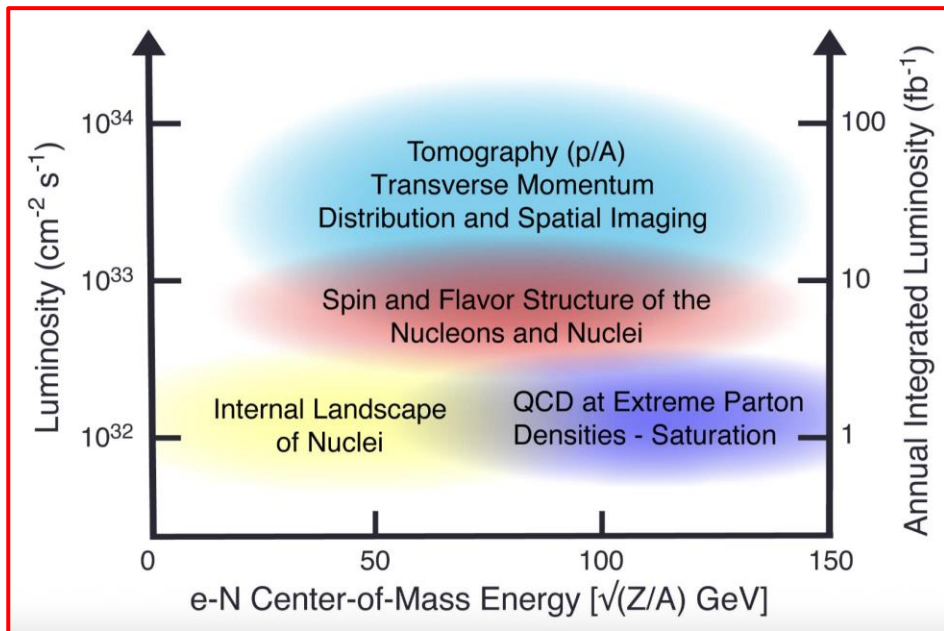

EIC Kinematics

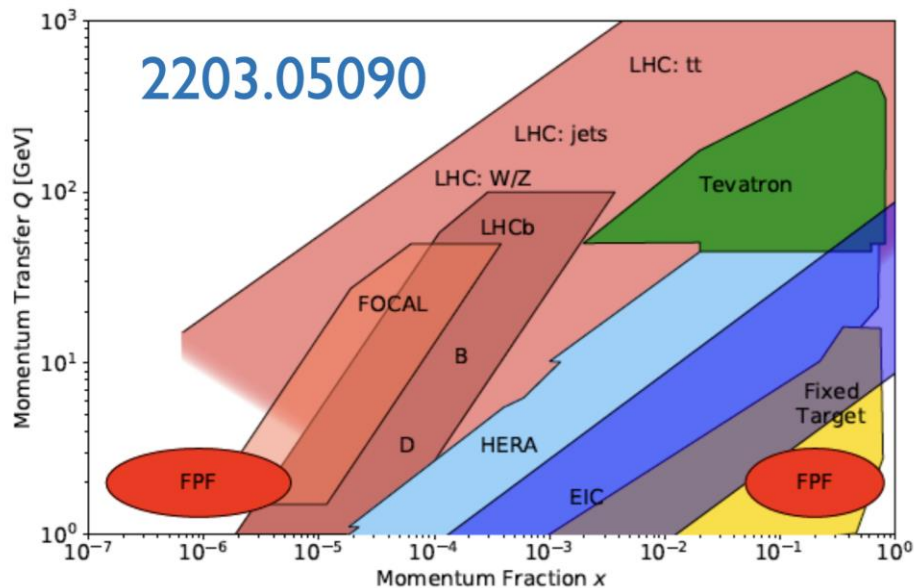
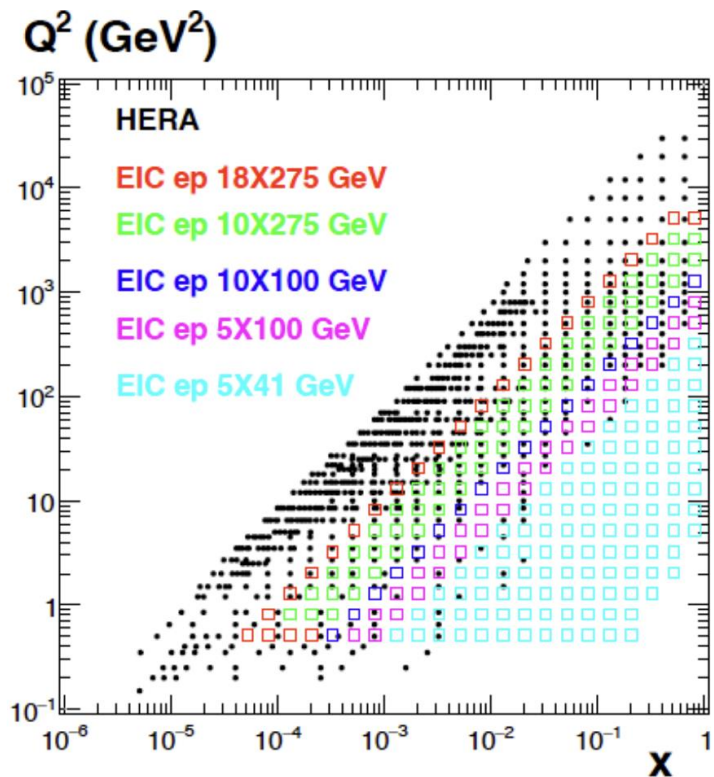

The EIC Luminosity and \sqrt{s}

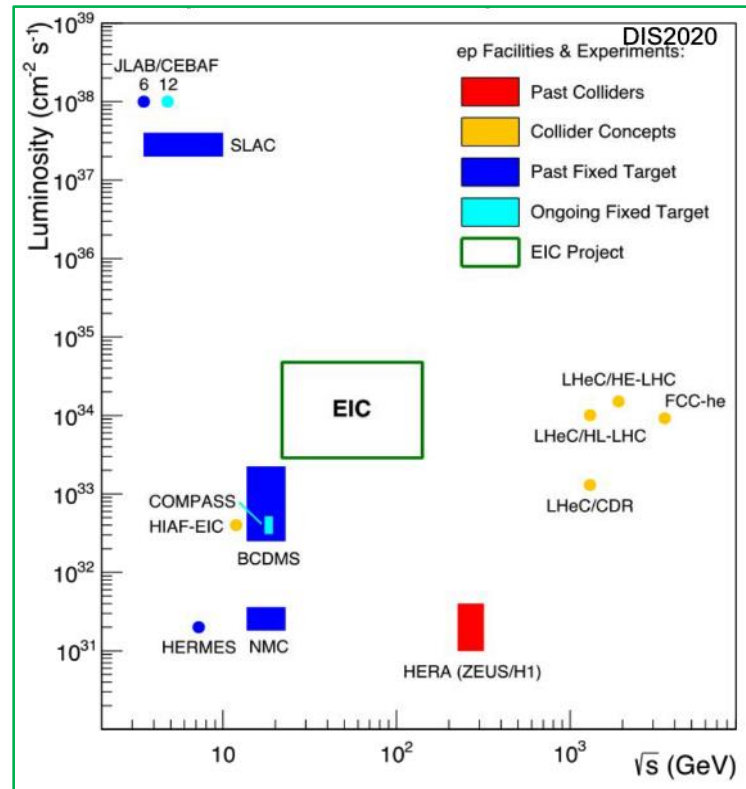

Accelerator Synergies

❖ Synergies with HL-LHC and FCC:

- **Crab Cavities**
 - Operation with crossing angle
 - Crab cavity design and operation
 - Crab cavity low level RF control, beam loading, noise suppression ...
- **Beam properties**
 - Bem-beam simulations and beam dynamics
 - Electron cloud mitigation
 - Ion sources
 - Machine protection, collimation, beam-dump...
 - Beam Instrumentation and Controls
 - Vacuum liners and coatings etc.
- **Superconducting Magnets and Superconductive Radio Frequency Cavities**
- **Machine Detector Interface**
- **Synchrotron Radiation simulations**

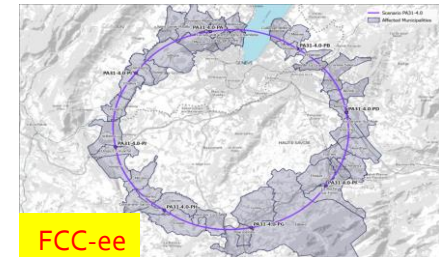
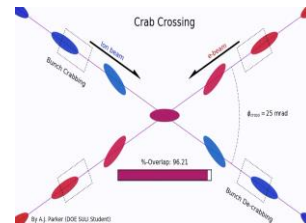

Running mode	Z	WW	ZH	t _i
Number of IPs	4	4	4	4
Beam energy (GeV)	45.6	80	120	182.5
Bunches/beam	11200	1856	300	60
Beam current [mA]	1292	135	26.8	5.1
Luminosity/IP [$10^{34} \text{ cm}^{-2} \text{ s}^{-1}$]	144	20	7.5	1.45
Energy loss / turn [GeV]	0.039	0.369	1.86	9.94
Synchrotron Radiation Power [MW]	100	100	100	100
Total beam lifetime [min.]	18	13	9	10
Total int. annual luminosity [ab^{-1}/yr]	68 ¹	9.6	3.6	0.67 ¹

Detector Synergies

HEP-NP synergies have become stronger given the phasing of physics projects and the overlap in physics drivers

- Several technologies originated in HEP and were adopted and advanced at EIC with significant innovations
- Some technologies are driven by the EIC project given that HEP projects are farther in the future

❖ Beam backgrounds



HERA and KEK experience shows that understanding beam backgrounds is crucial for the collider and detector performance
→ Working with FCC community on Synchrotron Radiation simulations

❖ Solenoid Magnet



→ First new big detector Solenoid after LHC > 15 years

❖ Monolithic Active Pixel Sensors (MAPS) Micro-Pattern Gaseous Detectors (MPGDs)



→ New MAPS development to the US together with CERN/ALICE ITS
→ Common generic R&D for fast MAPS for FCC
→ MPDGs synergy with CERN DRD₁, ATLAS New Small Wheel etc.

❖ Calorimetry



→ Generic R&D for Scintillating-glass for E.M. and Had. Calorimetry
→ Imaging calorimeter: full-size CALICE-like calorimeter in Forward Hcal
(History of development from Liner Collider → CMS → ePIC)

❖ Low Gain Avalanche Detector (LGAD) Photosensors:



→ First-time use of AC-LGAD in a collider detector
→ Common R&D on photosensors in HEP and NP, strong LHC-b interest

❖ Streaming readout



→ Process data as it arrives, interesting for future electron colliders

The ePIC Detector

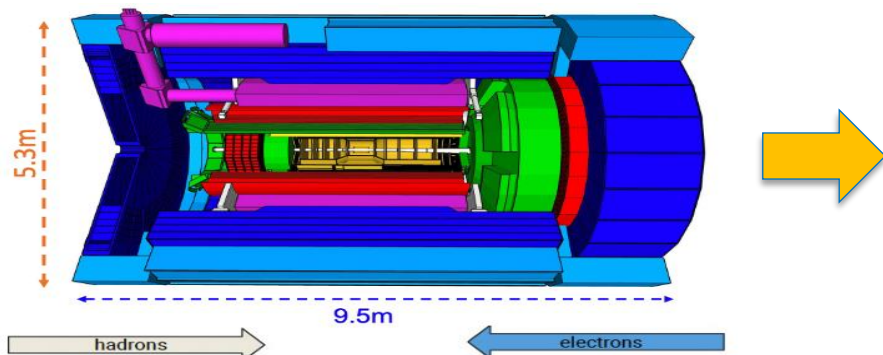

Far-Forward and Far-Backward Detectors

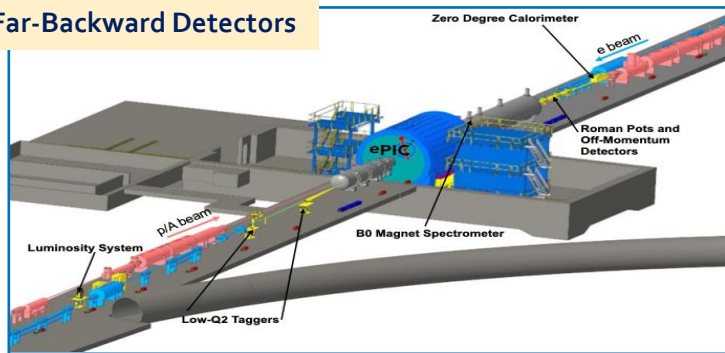

Central Detector

Tracking

- Si Monolithic Active Pixel Sensors (MAPS)
- Micro-Pattern Gaseous Detectors (MPGDs): μ RWELL/ μ Megas

Magnet

- New 2 T solenoid, 3.5 m long coil with 2.84 m diameter

Particle Identification

- High Performance Detection of Internally Reflected Cherenkov (DIRC) - barrel
- Dual radiator (aerogel+gas) RICH (forward)
- Proximity focusing RICH (aerogel) (backward)
- Time-of-Flight (TOF) with ~ 30 ps: AC-LGAD (barrel and forward)

EM calorimeter

- Imaging EMCAL (barrel)
- W-powder/SciFi (forward)
- PbWO_4 crystals (backward)

Had calorimeter

- Fe/Scint reuse from sPHENIX (barrel)
- Steel/Scint - W/Scint (backwards/forward)

DAQ: streaming/triggerless with AI

Global R&D

CERN

Detector R&D (DRD)
since 2023



DRD3

Semiconductor Det.

<https://drd3.web.cern.ch/>

Realization of the strategic developments, promoting blue-sky R&D in the field of solid-state detectors including the synergies with other fields of science

DRD3 WG1: Monolithic Detectors

WG1 research goals <2027	
	Description
RG 1.1	Spatial resolution: $\leq 3 \mu\text{m}$ position resolution
RG 1.2	Timing resolution: towards 20 ps timing precision
RG 1.3	Readout architectures: towards 100 MHz/cm ² , 1 GHz/cm ² with 3D stacked monolithic sensors, and on-chip reconfigurability
RG 1.4	Radiation tolerance: towards 10 ¹⁶ n _{eq} /cm ² NIEL and 500 MRad
RG 1.5	Low-cost large-area CMOS sensors

DRD3 WG2: Hybrid Detectors

WG2 research goals <2027	
	Description
RG 2.3	LGAD for 4D tracking < 10 μm , < 30 ps, wafer 6" and 8"
RG 2.4	LGAD for ToF (Large area, < 30 μm , < 30 ps)

US

CPAD R&D (RDC)
since 2022

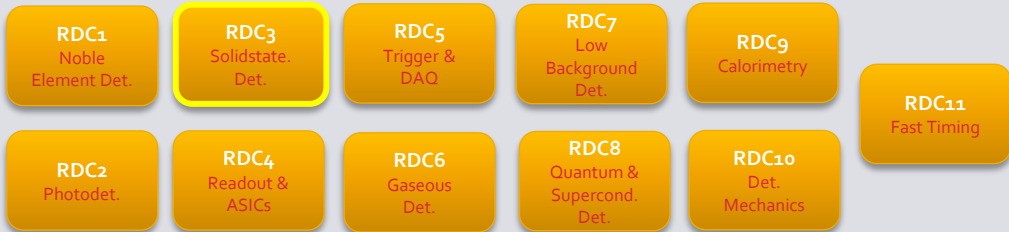

❖ Strategic goals for detector R&D are common between CERN and US and mostly common between HEP and NP, with overlap of effort (see [DOE Basic Research need – BRN 2019](#))

❖ ePIC is becoming a CERN recognized experiment (Accepted in 21st – 22nd March 2024 CERN Council Meeting)

1. Nucleon Structures at EIC and LHC

➤ Open Questions that EIC aims to address:

- **Are TMDs universal?**
(see collinear PDFs)?
- **How do TMDs evolve in Q^2**
(see DGLAP evolution of collinear PDFs)?
- **How is the transition between TMD and collinear PDF?**



- **Compare observables at EIC and LHC**
(e.g. in quarkonium or Higgs productions):
study how p_T distributions of bosons, e.g. the Higgs, are affected by gluon-TMDs with small intrinsic p_T
- Use azimuthal correlations in the Drell-Yan, di-photon and quarkonium (pair) productions at LHC with good momentum resolution in the full p_T range to **test the limits of applicability and the transition to the collinear PDF formalism** that applies at large p_T

- **While GPDs have reached high level of theoretical sophistication, measurements are limited by low statistics for exclusive processes and detector coverage**



- **Impact on Multi-Parton Interaction (MPI) at the LHC**
(independent hard scatters of colliding hadrons): transverse distance between partons is important (i.e. spatial distribution of single partons from GPDs)

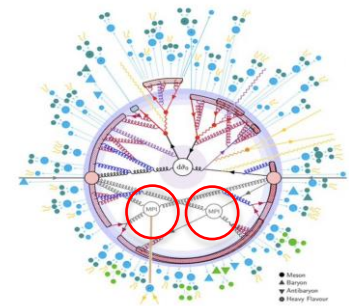

2. Flavor and Spin at EIC and LHC

❖ EIC will provide a very precise studies of the flavor dependence of Fragmentation Functions (FFs) over a large phase space

- Ultimate goal is a simultaneous extraction of PDFs and FF

❖ Polarized proton beams at the EIC will shed further light on their contribution to the Proton Spin

- Strange quark and gluon PDFs still have large uncertainties.
- RHIC gave evidence that the gluon contribution is nonvanishing and positive

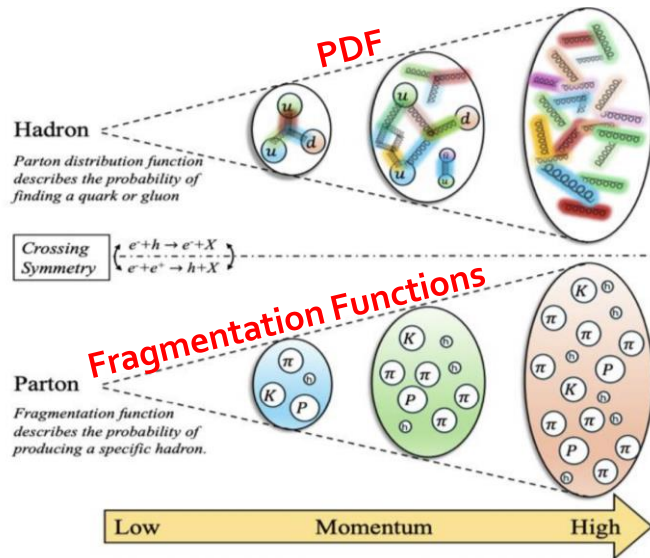
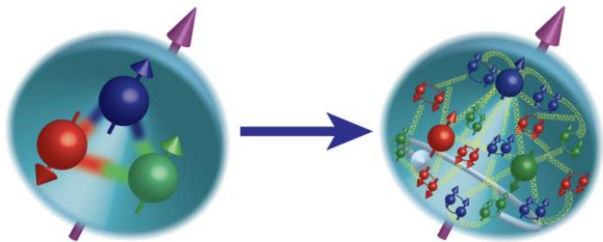

BSM searches at EIC – Long Lived Particles

❖ Heavy Neutral Leptons (HNL) at the EIC

- Both prompt and displaced HNL searches are possible
- Visible (leptons+jets) and invisible (monojet) decays may be possible, depending on ability to control systematic uncertainties of SM process

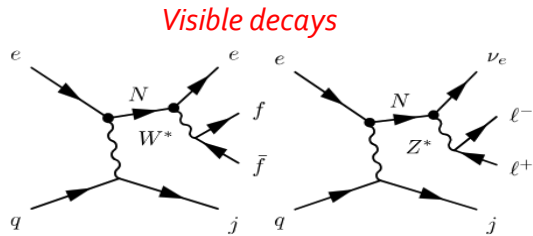
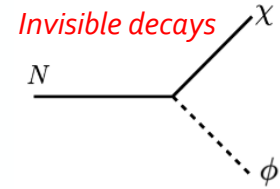

- Both prompt and displaced searches are possible

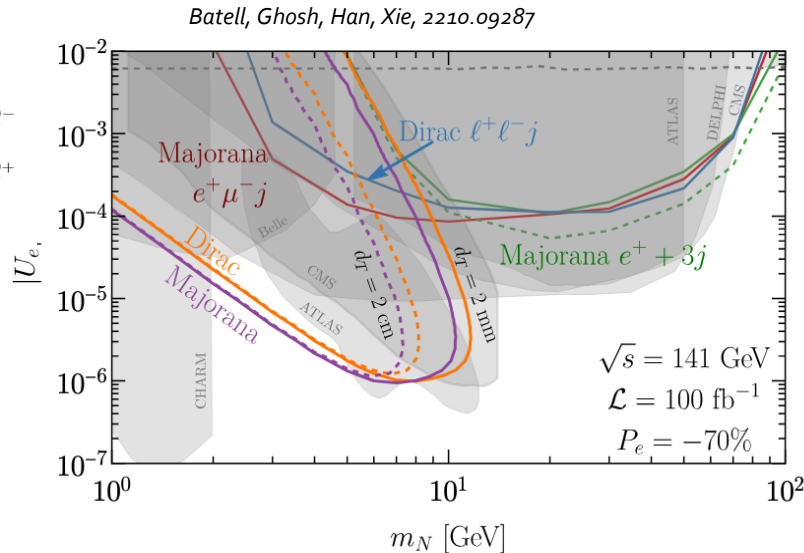

- Limits are compatible to those by LHC experiments